

Turbulent flow through a plane sudden expansion of modest aspect ratio

M. P. Escudier

Department of Engineering, Mechanical Engineering, University of Liverpool, Brownlow Hill, Liverpool, L69 3GH, United Kingdom

P. J. Oliveira

Departamento de Engenharia Electromecânica, Universidade da Beira Interior, Rua Marquês D'Ávila e Bolama, 6200 Covilhã, Portugal

R. J. Poole

Department of Engineering, Mechanical Engineering, University of Liverpool, Brownlow Hill, Liverpool, L69 3GH, United Kingdom

(Received 12 October 2001; accepted 15 June 2002; published 5 September 2002)

The results are reported of an experimental investigation of turbulent flow through a plane sudden expansion of expansion ratio $R = D/d = 4$ and aspect ratio $A = w/h = 5.33$. It is well known that plane sudden expansions of high aspect ratio ($A > 10$) with R greater than 1.5 produce asymmetric flows and this was again seen in this study. The literature for the asymmetric flow situation is surprisingly limited and only axial velocity and axial turbulence intensity results have been reported previously. A laser Doppler anemometer was used here to measure mean and rms axial velocities, U and u' , as well as the transverse mean and rms velocities, V and v' , and the Reynolds shear stress, uv . Not only was the mean flow found to be strongly asymmetric, but integration of the mean axial velocity profiles revealed significant departures from two dimensionality along the centerplane of the expansion duct. Results are reported at three spanwise locations to highlight this three dimensionality and qualitative arguments are made to relate this to the influence on corner vortices of the modest aspect ratio. © 2002 American Institute of Physics. [DOI: 10.1063/1.1504711]

I. INTRODUCTION

Although turbulent flow through a plane sudden expansion is relevant to a number of important engineering applications, including fluidic devices, heat exchangers, mixing equipment and air-conditioning ducts, the number of investigations of turbulent flows through plane sudden expansions reported previously (summarized in Table I) is surprisingly limited. A key geometric parameter is the expansion ratio R where $R = D/d$, D being the downstream channel height and d the inlet height. Abbott and Kline¹ were the first to investigate systematically the influence of R on flow through a plane sudden expansion. They used a modified hot-film anemometer and a dye-injection technique to observe flow patterns for different expansions covering R values in the range $1.125 < R < 5$. They found that for $R > 1.5$ the flow became asymmetric with two recirculation zones of unequal length, while below this value the flow approached that for a double backward-facing step configuration with symmetrical regions of recirculation. Abbott and Kline also observed that near reattachment the flow was not two dimensional. Their findings have been confirmed by other investigators and it is now generally accepted that flow through a plane sudden expansion must be divided into two regimes depending on the expansion ratio.

It can be seen from Table I that for the asymmetric situation ($R > 1.5$) reliable data have been reported previously for axial mean velocity U and turbulence intensity u' but not for the transverse component of mean velocity V , the trans-

verse component of the turbulence intensity v' or the Reynolds shear stress uv . Tutu and Chevray² and Eaton and Johnston³ have discussed the inadequacies of the hot-film technique used by Abbot and Kline for their turbulence measurements. In the present study, for which $R = 4$, this lack of reliable data is addressed by including distributions of mean transverse velocity V and turbulence intensity v' and the Reynolds shear stress uv together with the wall-pressure variation $p(x)$.

Smyth⁴ and Szymocha⁵ both reported symmetric flow patterns for ducts with $R = 1.5$. Smyth's comprehensive work fully documents the symmetric case and includes measurements of all three velocity fluctuations u' , v' , w' , the Reynolds shear stress uv and the turbulent kinetic energy k at 13 axial locations. Although the flow is said to be only "approximately" two-dimensional along the center plane of the duct, no flow rate comparisons between integrated velocity profiles at different axial locations were made to quantify any deviation from two dimensionality. Szymocha's flow had a uniform inlet velocity which resulted in a slight reduction in the length of the recirculation zone compared with that for the fully developed inlet conditions of Smyth.

Restivo and Whitelaw⁶ were the first to investigate the asymmetric situation ($R = 3$) using laser Doppler anemometry (LDA). A major focus of their work was the turbulence energy spectrum which, they found, did not display significant peaks at the highest Reynolds number ($Re = 3995$). At lower Reynolds numbers, the energy spectra showed discrete

TABLE I. Turbulent plane sudden expansion literature review.

Author(s)	d (mm)	D (mm)	h (mm)	w (mm)	R (D/d)	A (w/d)	A (w/h)	Re (based on d, U_B)	Inlet velocity profile	Experimental technique	Reported data	Reattachment lengths (x/d)	Reattachment lengths (x/h)
Abbot and Kline (1962)	76	85.5–380	4.75–152	305	1.125–5	4	2 to 16	20 000–50 000	Fully developed	Hot wire Dye injection	U, u', v, v'	4.8, 15.3	3.2, 10.2 (Ratio 1:3.1875)
Restivo and Whitelaw (1978)	4	12	4	110	3	27.5	27.5	3000	Uniform	LDA	U, u' , spectra		
Smyth (1979)	10	15	2.5	76	1.5	7.6	30.4	20 140	Fully developed	LDA	U, u', v', w' $\frac{uv}{uv}$	1.5	6
Mehta (1981)	100	200	50	25	2	0.25	0.5	125 000	Fully developed	Pitot tube, Hot wire	U, p u', v', \overline{uv}	3.6 9.30	3.6 (Ratio 1:2) 4.5, 15 (Ratio 1:3.33)
Szymocha (1984)	60	90	15	160	1.5	2.67	10.67	42 000	Uniform	LDA	U, u'	1.38–1.5	5.5–6
Alouri and Souhar (2000)	44	100	28	5	2.27	0.11	0.18	32 000	Fully developed	Hot fil	U, u', p	3.4, 6.87	5.4, 10.8 (Ratio 1:2)
De Zilwa <i>et al.</i> (2000)	14	40	13	160	2.86	11.43	12.31	26 500	Uniform	LDA	U, u'	3.16, 15.8	3.4, 17 (Ratio 1:5)
Current study	10	40	15	80	4	8	5.33	55 500	Uniform	LDA	U, u', v, v' uv, p	4.7, 17.3	3.13, 11.5 (Ratio 1:3.07)

peaks with relatively low energy at higher and lower frequencies. Limited profiles of axial velocity U and turbulence intensity u' were reported for a Reynolds number of 2995. Although no mention is made in the paper itself of the two dimensionality of the flow, it is clear from the results that the flow rate, calculated by integrating velocity profiles, varies by up to 20% with axial location.

In most previous work the aspect ratio ($A = w/h$, w being the duct width and h being the step height) has been either less than 1 or greater than 10 (see Table I). In practice the aspect ratio is likely to fall in the range 1–10 and in the present work the value chosen was 5.33. Mehta⁷ and Alouri and Souhar⁸ both report flows through sudden expansions with $A < 1$ which can be classed as flat duct sudden expansions and are included here only for completeness. In this configuration, the duct is very narrow and the transverse distribution of velocity roughly power law in form according to Alouri and Souhar, as it would be for fully developed turbulent flow in a two-dimensional channel. The numerical simulation of Gagnon *et al.*⁹ using a two-dimensional random vortex method, employed the data of Mehta as the basis for

comparison. The poor agreement between the calculations and experiments was attributed to three dimensionality of the experimental flow.

The most recent and relevant work to be reported is that of De Zilwa *et al.*¹⁰ who presented LDA measurements of axial-mean velocity and axial-turbulence intensity for a duct with $R = 2.86$ and $A = 12.3$ at a Reynolds number of 26 500 together with numerical results based on the standard $k-\epsilon$ method. The agreement between the experimental results and the numerical data is not completely satisfactory, the differences being attributed to deficiencies in the $k-\epsilon$ method when dealing with turbulence anisotropy and streamline curvature. The flow is said to be two-dimensional over the middle 80% of the duct but the authors comment that integration of the velocity profile far downstream of the expansion showed a discrepancy of 15% compared with the measured flow rate.

One of the objectives of the present paper is to investigate the assumption that nominally two-dimensional sudden expansions produce two-dimensional flows. Previous papers which explore this topic have all been concerned with the

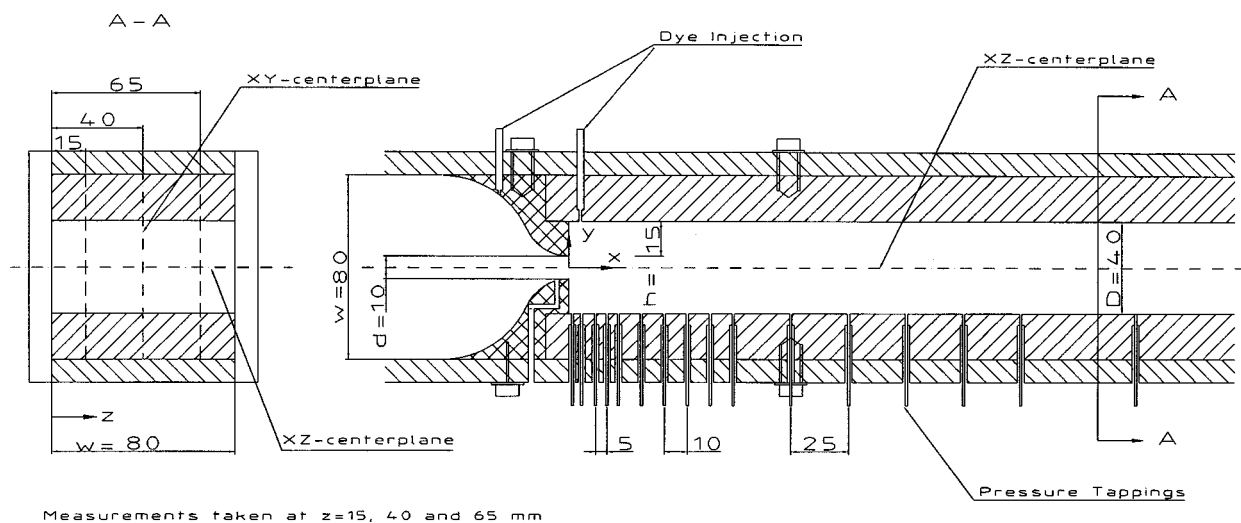

FIG. 1. Plane sudden expansion geometry, dimensions in mm.

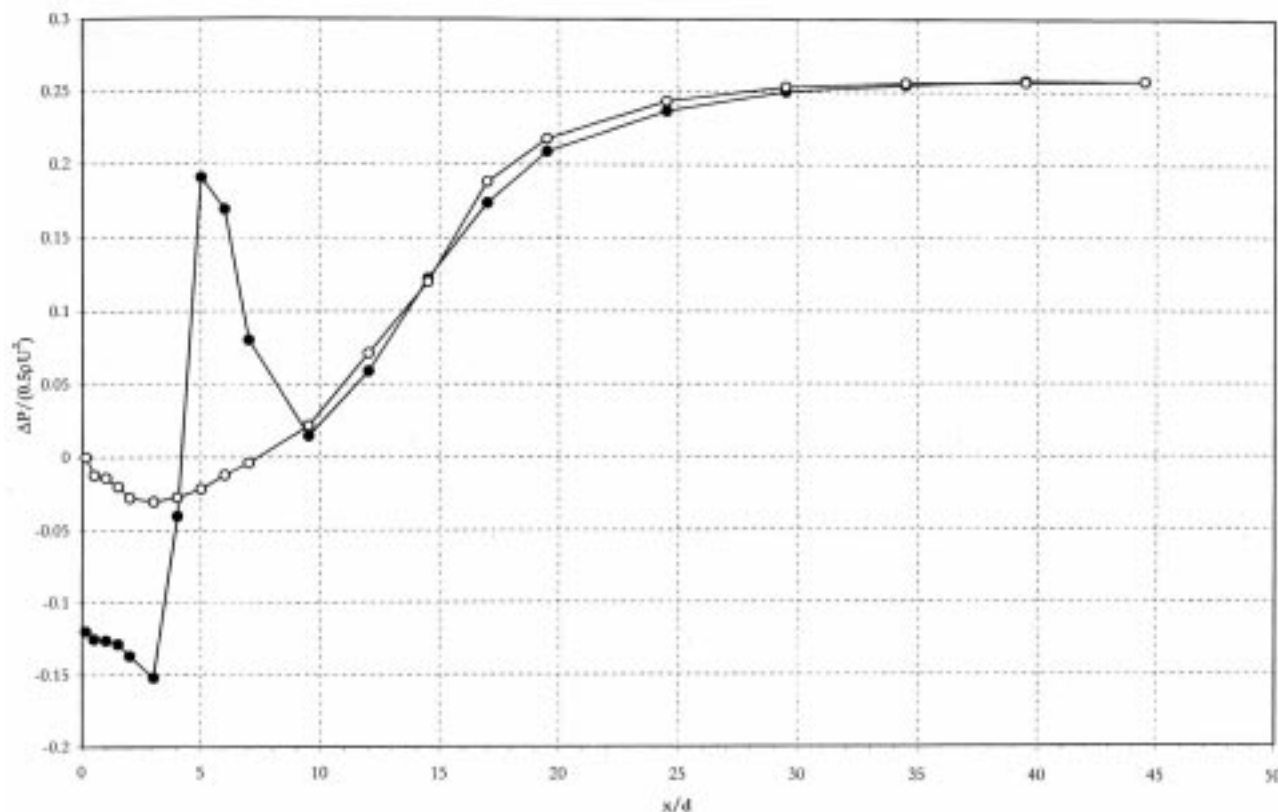

FIG. 2. Wall-pressure variation (closed symbols lower wall).

two dimensionality of flow behind backward-facing steps. de Brederode and Bradshaw¹¹ studied the effects of small aspect ratio on the flow downstream of a backward-facing step using surface flow patterns and heat-transfer measurements. They concluded that complicated stress-induced corner flows were confined to a distance of about 2 or 3 step heights from the sidewalls and that sidewall effects on the flow near the center plane were negligible for aspect ratios greater than 10. Papadopoulos and Otugen¹² investigated sidewall effects on the turbulent flow over a backward-facing step for a range of aspect ratios ($1 < A < 28$) but their use of a hot-wire probe precluded measurements of the velocity within the recirculation region. From their measurements, combined with trends inferred from surface visualization, Papadopoulos and Otugen concluded that the flow downstream of reattachment was three dimensional.

II. EXPERIMENTAL RIG AND INSTRUMENTATION

The flow loop used for the present experiments was a modified version of that used by Escudier and Smith¹³ for their square-duct investigation. The square duct consisted of 10 stainless steel modules each of length 1.2 m and with an internal cross section of side length $w = 80$ mm. The plane sudden expansion, for which the key dimensions are given in Fig. 1, replaced one of the existing modules 9.6 m from the inlet connection. The duct width w throughout was 80 mm, the inlet height d was 10 mm, and the step height h was 15 mm. The downstream duct height D was 40 mm. It should be emphasized that the duct geometry was symmetrical

about the XY and XZ center planes. The expansion was preceded by a short (53.5 mm in length), smooth contraction (40 mm radius followed by 20 mm radius) which led to a distribution of velocity at the plane of the sudden expansion which was practically uniform and of low turbulence intensity. The sidewalls of the expansion were made of borosilicate glass to permit velocity measurements using a laser Doppler anemometer. Distributions of mean velocity and turbulence structure were obtained from traverses at 14 axial locations (corresponding to x/d values of 0, 0.5, 1, 2, 3, 4, 5, 6, 7, 10, 12, 15, 18, and 21) at three spanwise locations, $z/d = 4, 1.5,$ and 6.5 , which correspond to the XY center plane of the duct and two parallel planes one step height from each of the sidewalls (see Fig. 1). Spanwise profiles were obtained on the XZ center plane (i.e., $y/D = 0.5$) upstream of the contraction ($x/d = -10$) and at inlet ($x/d = 0$) and also at $x/d = 2$ over the range $0.05 < y/D < 0.95$.

A Dantec Fibreflow laser Doppler anemometer system was used for the velocity and turbulence measurements and comprised a Dantec 60X10 probe and a Dantec 55X12 beam expander in conjunction with two Dantec Burst Spectrum Analyzer signal processors (one model is 57N10, the other model is 57N20). The beam separation at the front lens was 51.5 mm and the lens focal length 160 mm (i.e., included half angle 9.14°) which produces a measurement volume with principal axis of length 0.21 mm and diameter 0.02 mm. The axial and transverse velocity values were collected in coincidence to enable the Reynolds shear stress values to be estimated. As recommended by Tropea,¹⁴ transit-time

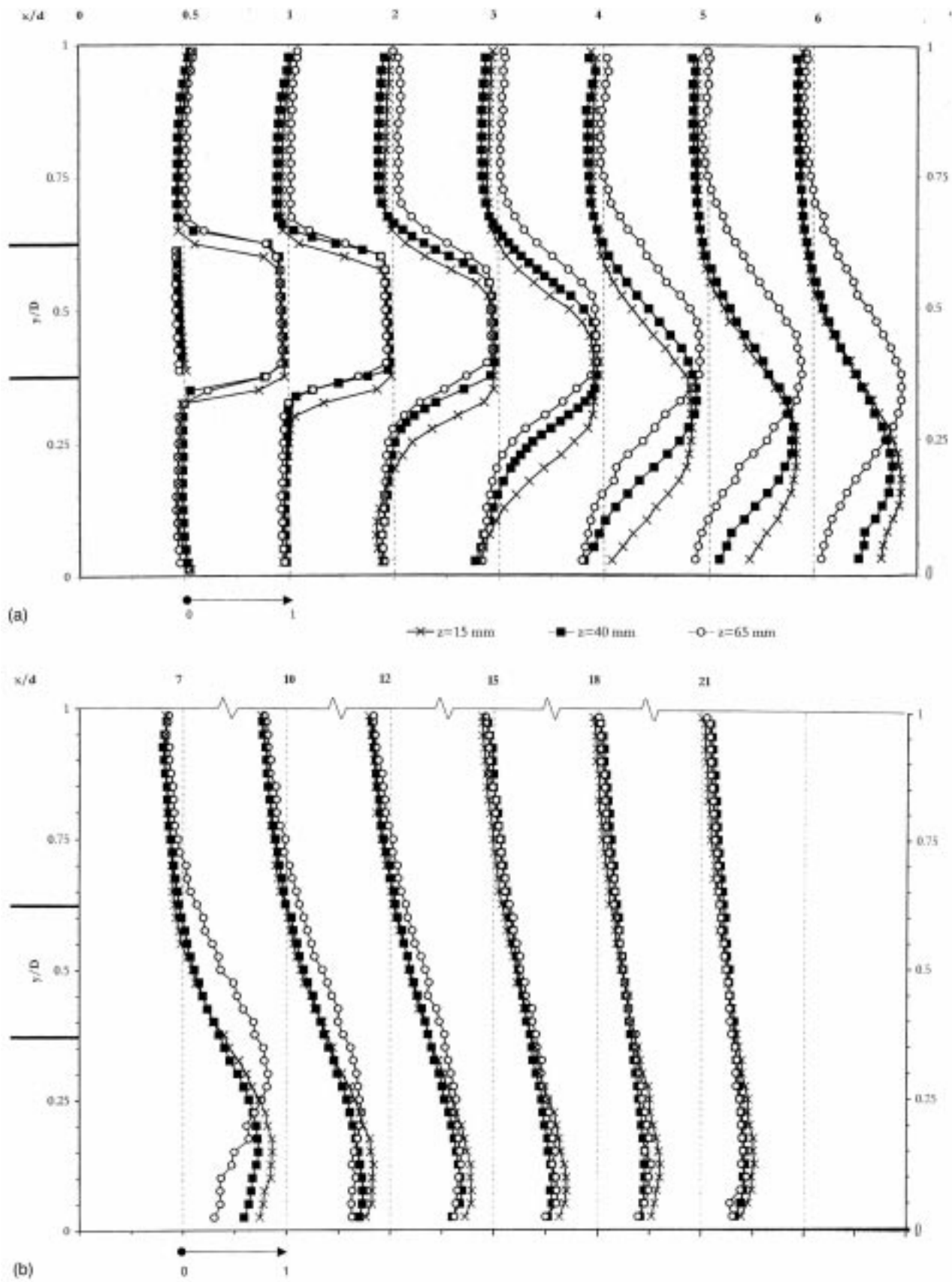

FIG. 3. (a) and (b) Mean axial velocity profiles (U/U_B) .

TABLE II. Measured reattachment lengths and peak turbulence at different spanwise locations.

z (mm)	x_{RL} (x/d)	X_{RU} (x/d)	$\frac{u'_{MAXL}{}^a}{U_B}$	$\frac{u'_{MAXU}}{U_B}$	$\frac{v'_{MAXL}}{U_B}$	$\frac{v'_{MAXU}}{U_B}$	$\frac{\overline{UV}_{MAXL}}{U_B^2}$	$\frac{\overline{UV}_{MAXU}}{U_B^2}$
15	3.7	20	0.219	0.245	0.183	0.136	0.0235	0.0109
40	4.7	17.3	0.216	0.261	0.191	0.143	0.0227	0.0119
65	5.6	17.5	0.229	0.218	0.161	0.131	0.0219	0.0106

^aSubscript MAXL indicates the maximum value in the lower recirculation region and MAXU indicates the maximum in the upper recirculation region.

weighting was used to correct the velocity measurements for the effects of velocity bias. In view of the small diameter of the measuring volume, no correction was applied for the effect of velocity gradient broadening. Nominally 10 000 velocity samples were collected per point which resulted in a maximum relative statistical error, for a 95% confidence interval, of approximately 0.5% in the mean velocity and 1.4% in the turbulence intensity (Yanta and Smith¹⁵).

As shown in Fig. 1, 19 pressure tappings of 1 mm diameter were provided along the XY center plane of the expansion to allow the wall pressure variation to be measured. The tappings were connected to 2 mm ID clear vinyl tubing, filled with deionized water, linking each in turn via a series of valves to a Validyne differential pressure transducer (model DP15-26). Flow rates were measured using a Fischer and Porter electromagnetic flow meter (model 10D1) incorporated in the flow loop upstream of the sudden expansion with the flowmeter output signal recorded via an Amplicon PS 30AT A/D converter.

The working fluid was filtered tap water with 100 ppm of 40% formaldehyde solution added to suppress bacterial activity. Approximately 0.25 g of Timiron seeding particles were added to the fluid to improve the LDA signal quality.

III. RESULTS

All data presented here refer to a Reynolds number of 55 500 based on the mean bulk velocity at the expansion, $U_B = 5.57$ m/s, and the duct height immediately upstream of the expansion, $d = 10$ mm.

A. Wall-pressure variation

It is surprising that measurements of the wall-pressure variation have not been reported previously for the asymmetric ($R > 1.5$) situation. De Zilwa *et al.* present a numerical prediction for the pressure distribution on the upper and lower duct walls but provide no experimental validation. Although their prediction is in qualitative agreement with the

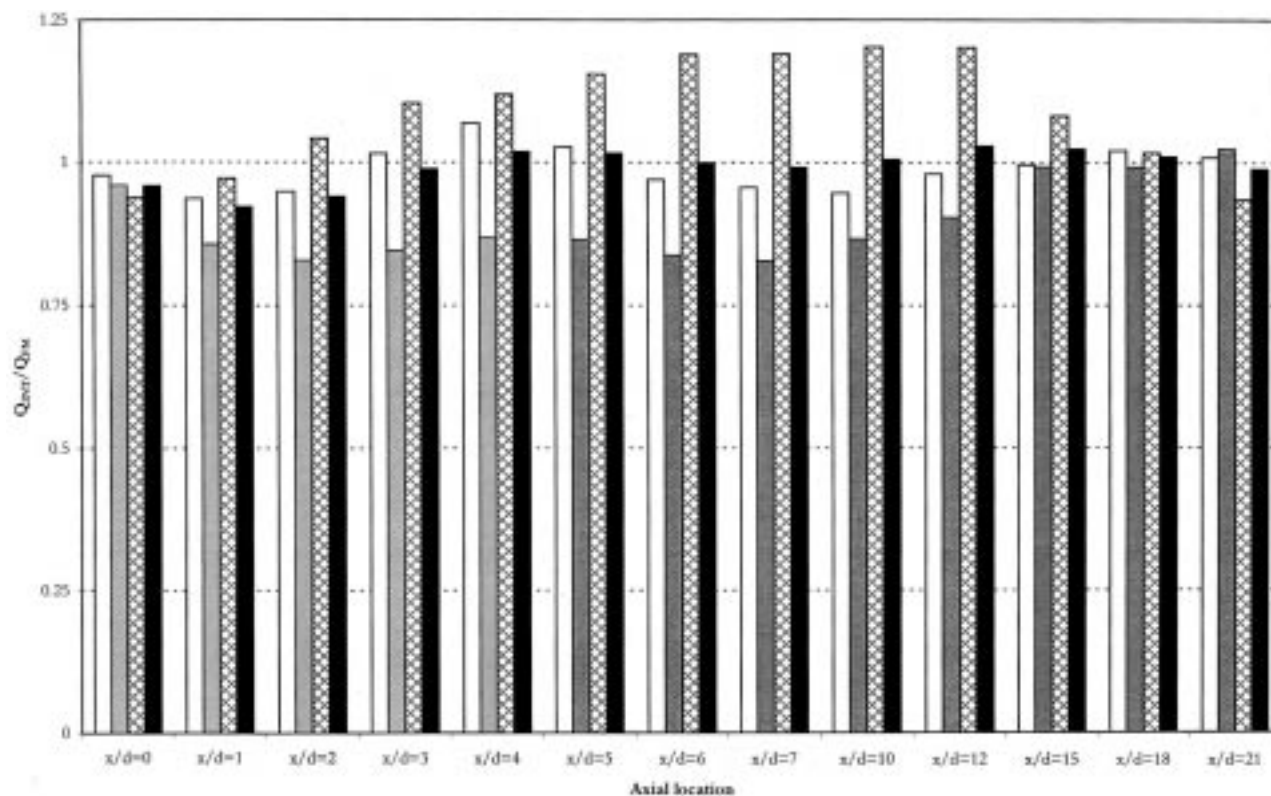

FIG. 4. Comparison between flow rate from flow meter and from integration of velocity profile (chart order: $z = 15, 40, 65$, average).

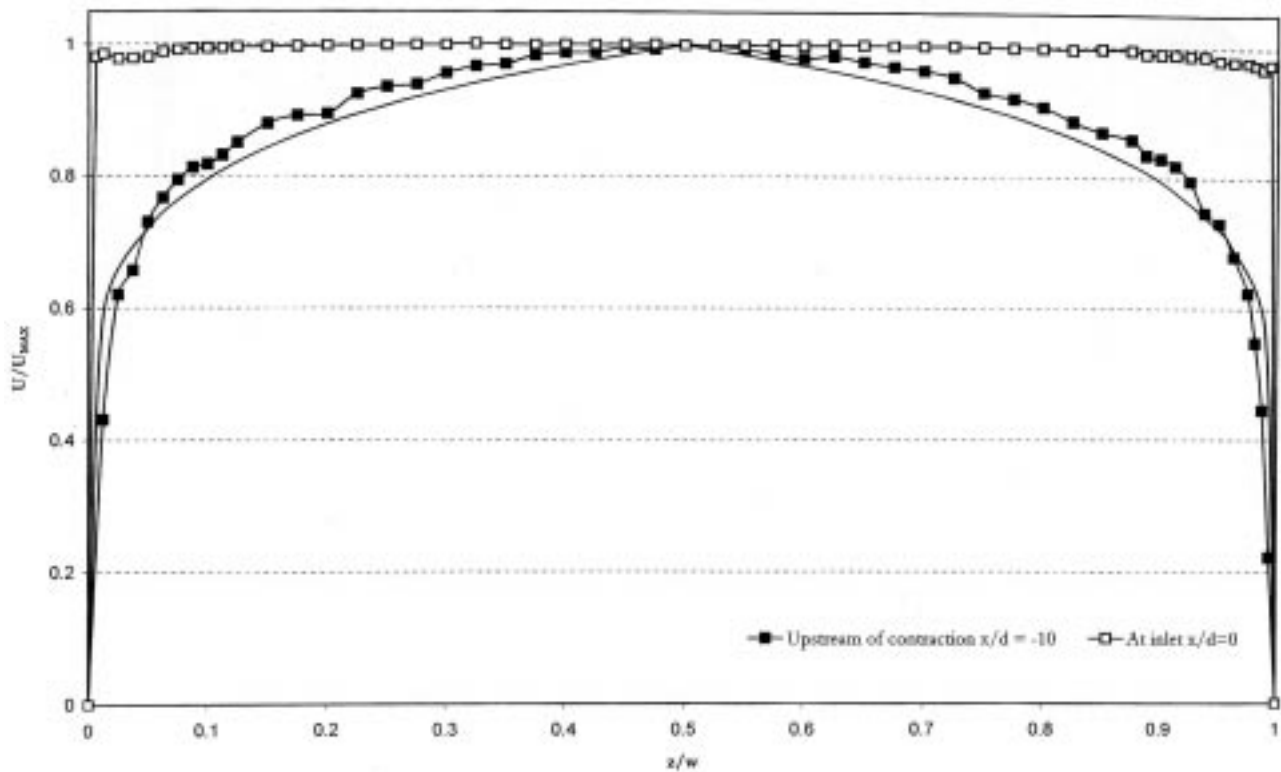

FIG. 5. Spanwise variation along XZ center plane ($y/D=0.5$) of mean axial velocity profile (U/U_B) upstream of contraction and at inlet including power-law fit.

present measurements, this is as much as can be expected given the different expansion ratio and the uncertainty of calculations based on the standard $k-\epsilon$ turbulence model.

The flow asymmetry is apparent from the measured pressure distribution along the XY center plane of the duct for both top and bottom walls shown in Fig. 2. The pressure within the shorter recirculation zone is much lower than in the longer. Since the shorter region of recirculation was equally likely to occur on the top and bottom walls, a pressure check was used to determine the flow configuration on start up and then, for consistency, the shorter region plotted as though occurring on the lower wall. This convention is applied for all data reported here.

The pressure distribution on the upper wall closely resembles that found in a backward-facing step flow (see, for example, Chun and Sung¹⁶). The pressure gradient on the lower wall is high immediately downstream of the expansion, the pressure reaching a maximum at the point where the flow reattaches (approximately $x/d=5$). After the high-velocity core of the shear layer impinges on the wall, the pressure falls until $x/d=10$ downstream of which the pressure has recovered significantly to become identical to that on the opposite wall.

B. Mean axial velocity profiles, U/U_B

The mean axial velocity profiles of Figs. 3(a) and 3(b) are all asymmetric with unequal recirculation regions on the top and bottom walls in accordance with previous studies (see, for example, De Zilwa *et al.*). Immediately apparent is

that not only do the velocity profiles vary significantly across the span of the duct but also that they are not symmetrical about the XY center plane (i.e., $z=40$ mm). This spanwise asymmetry is also confirmed, see Table II, by the variation in the time averaged reattachment lengths for the three profiles. Also, as Spazzini *et al.*¹⁷ and others have found in studies of flow over a backward-facing step, it was observed that the reattachment lengths varied with time. This time variation was investigated using spectral analysis in which a fast Fourier transform technique was used to decompose the velocity signal near the point of mean reattachment on the lower wall ($x/d=4.7$, $y/D=0.0125$, and $z=40$ mm) into its fundamental frequencies. A significant peak occurred at a distinct frequency of $f \cong 8.16$ Hz (corresponding to $fh/U_B \cong 0.022$). Due to the three-dimensional nature of the results, the stream function was not evaluated so that no streamline patterns can be presented. The flow field is clearly very complex with the profiles for $z=40$ and 15 mm initially quite similar but with the peaks in the profiles for $z=15$ mm following a slightly lower trajectory, impinging on the wall earlier and resulting in a shorter reattachment length, x_{RL} , about 20% lower than for the XY center plane profile itself. The profile on the $z=65$ mm side of the duct follows a significantly different development with its maximum velocity located nearer the XZ center plane resulting in an increase of the reattachment distance compared to the XY center plane of about 20%. At $x/d=0.5$ all three profiles have positive axial velocities adjacent to both the lower and upper wall (i.e., $y/D=0$ and 1)

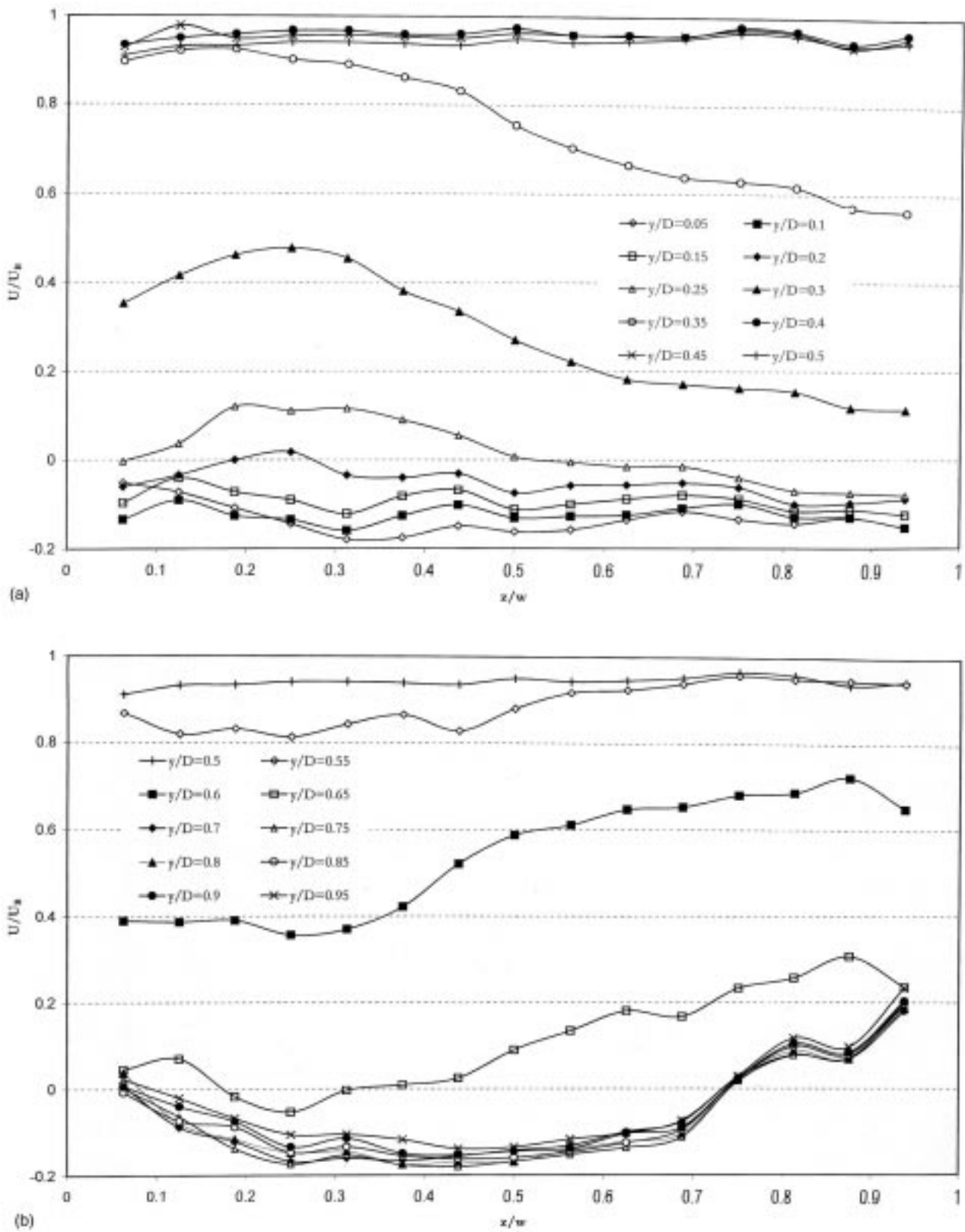

FIG. 6. (a) and (b) Spanwise variation of mean axial velocity profiles (U/U_B) at $x/d=2$ for various transverse (y/D) locations.

indicating the existence of small corner-eddies as has been observed previously in backward-facing step flows (see Tihon *et al.*¹⁸).

The spanwise differences across the duct in the longer

recirculation region are less pronounced than in the shorter recirculation region and are again related to the location of the shear layer that is, in itself, determined by the trajectory of the high velocity core. The lower trajectory of the z

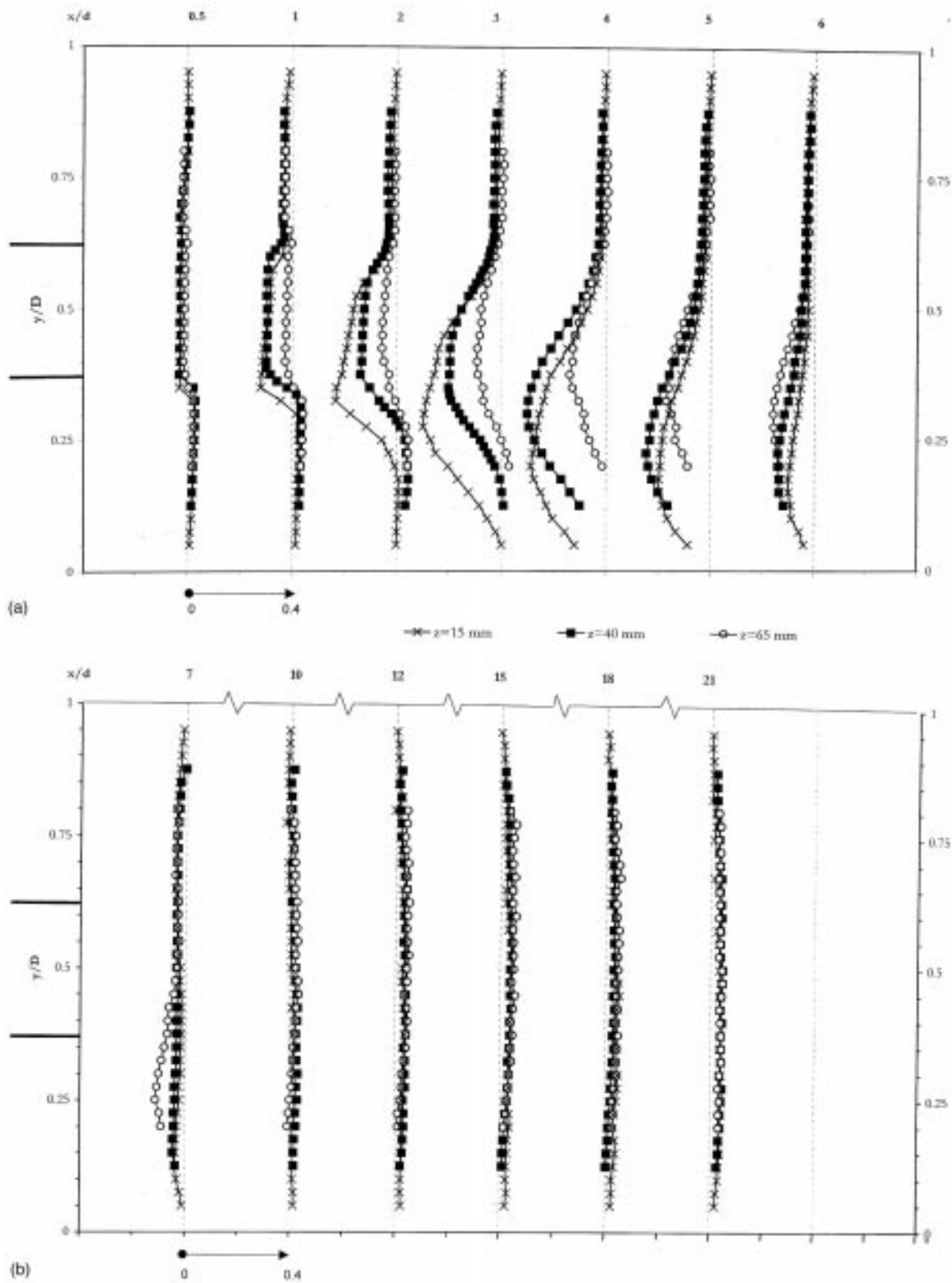

FIG. 7. (a) and (b) Mean transverse velocity profiles (V/U_B) .

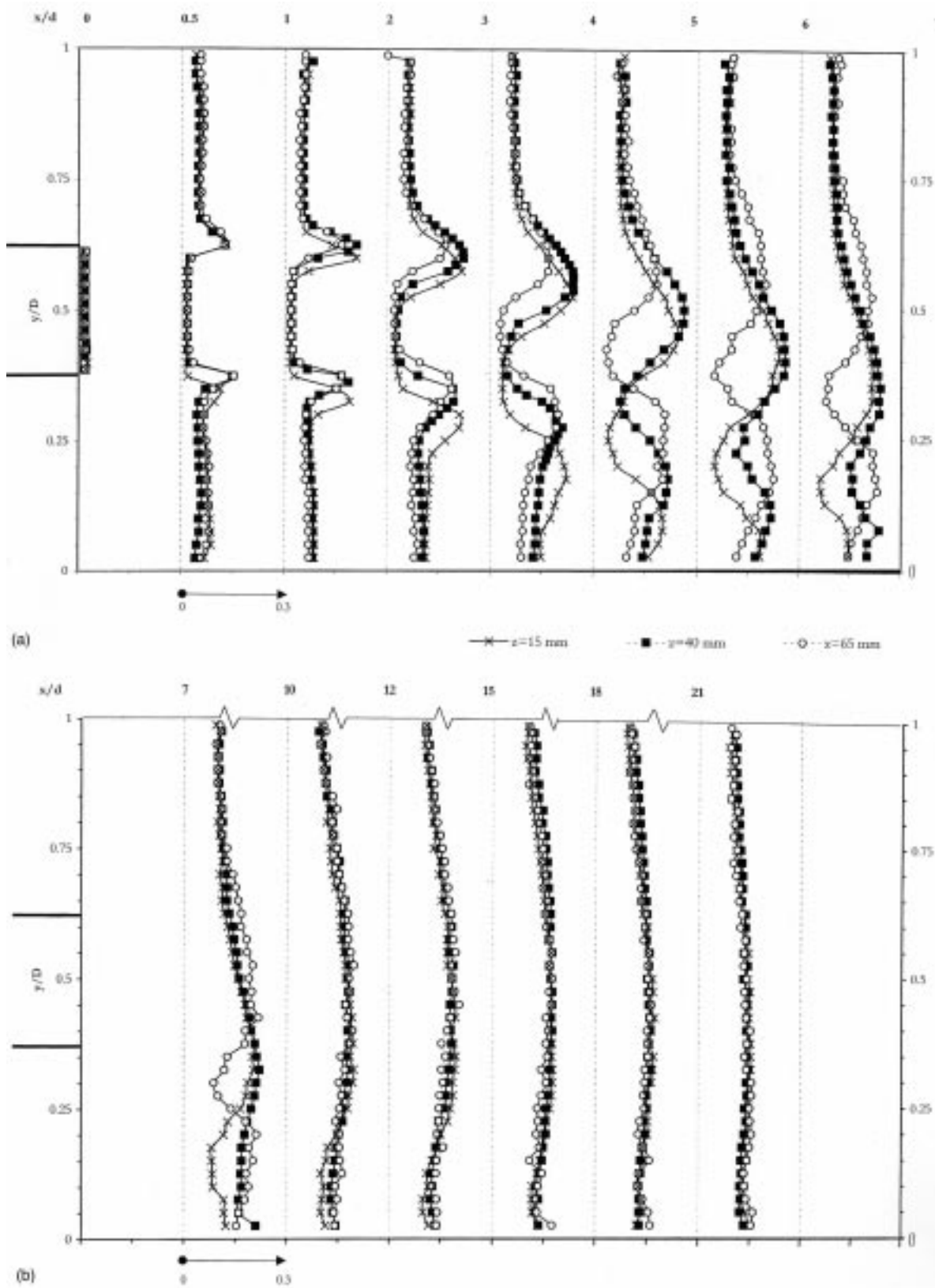

FIG. 8. (a) and (b) rms axial turbulence intensity profiles (u'/U_B).

=15 mm profiles has the inverse effect on the upper wall, namely to increase the reattachment distance relative to the XY center plane by approximately 15%. Close to the wall, between $x/d=4$ and 12, the profiles at $z=15$ and 40 mm are

very similar until reattachment. The axial velocity on the $z=65$ mm side is positive immediately after the expansion and reverse flow on the upper wall does not occur until $x/d=5$, after which the profiles resemble those at $z=15$ and

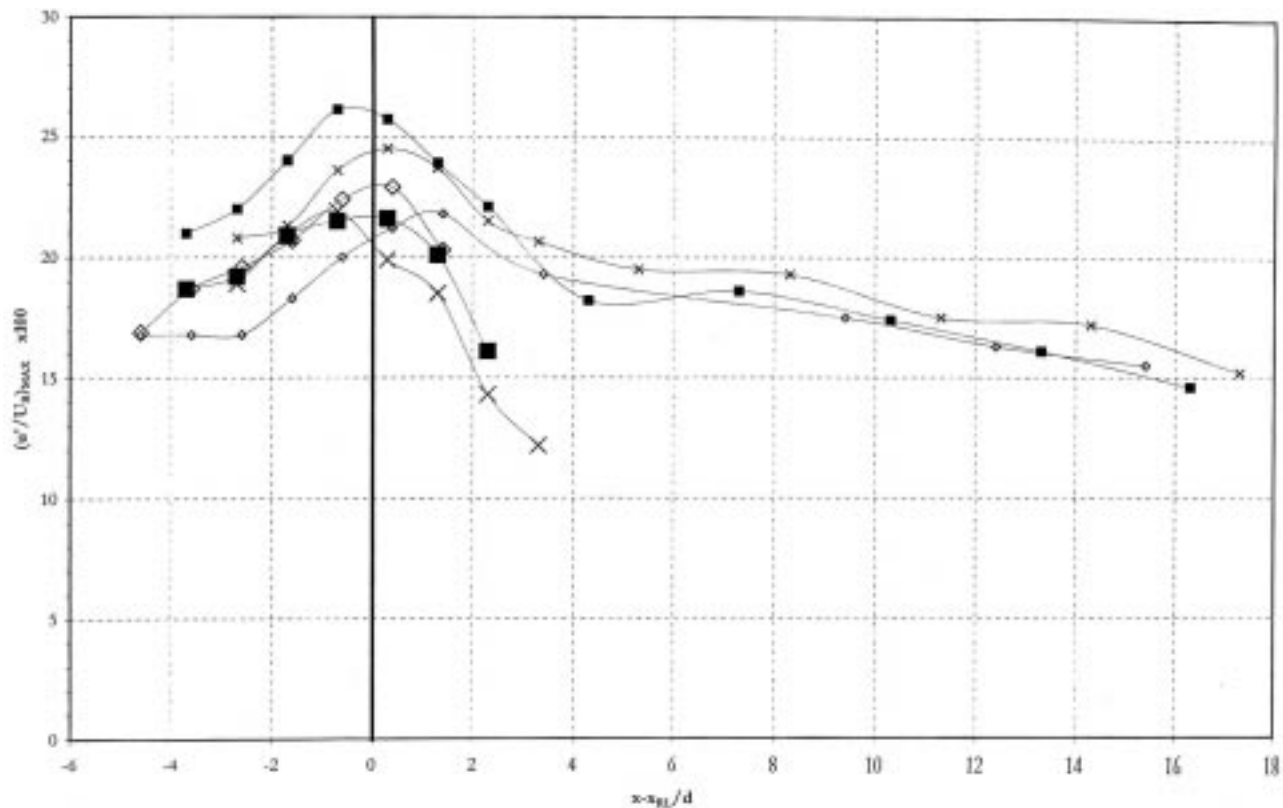

FIG. 9. Maximum axial turbulence intensities. (Note: large symbols lower recirculation region.)

40 mm before the flow reattaches at approximately the same location as for the XY center plane.

Figure 3(b) shows that as the flow progresses downstream the differences diminish and the flow becomes progressively more two dimensional. By $x/d=21$ the differences in the velocity profile across the duct are slight although the flow is still asymmetric from top to bottom, showing that the effect of the expansion is still influencing the flow.

To further investigate flow two dimensionality, each of the mean axial velocity profiles was integrated numerically producing the results seen in Fig. 4. Also plotted is the average of the three apparent flow rates as a means of gross comparison. The figure reveals deviations from two dimensionality of up to 20% downstream of the expansion. Upstream of $x/d=15$ the flow rate is as much as 20% below that expected along the XY center plane of the duct which is surprising, as it would be expected that the sidewall boundary layers would retard the flow nearest the sidewalls and accelerate the flow in the duct center. By $x/d=21$ the three flow rates are within 5% of each other and the value from the flow meter. Results taken in the same experimental rig (to be reported at a later date) for a plane sudden expansion, of expansion ratio (D/d) 1.5 and aspect ratio (w/h) 13.33, showed symmetry about the XZ center plane and a deviation in flow rate less than 5%, which suggests that the deviations observed in the present case are not simply a consequence of imperceptible geometric imperfections. We note too that the magnitude of the departure from two dimensionality observed in our measurements is comparable with that evident

in the results of Restivo and Whitlaw and of De Zilwa *et al.*, although this could be attributable to the noncorrection for velocity bias in both of these works. Two spanwise mean axial velocity profiles were obtained in the XZ center plane ($y/D=0.5$) and are shown in Fig. 5. Well upstream of the contraction ($x/d=-10$), in the square duct itself, the flow is symmetric and fully developed (a power-law fit is included to highlight the symmetry of the profile). The effect of the contraction is to produce an inlet profile ($x/d=0$) which is practically uniform ($\approx 0.99U_B$) with very thin sidewall boundary layers and of low turbulence intensity ($u'/U_B = 2.5\% \pm 0.5\%$). Both profiles are clearly symmetric and indicate the unlikelihood that the spanwise asymmetry observed downstream is due to upstream influences.

Immediately downstream of the step, two opposing mechanisms appear to be acting in the upper and lower recirculation zones. In the upper region, the flow is reversed on the $z=15$ mm side and in the center but is in the positive streamwise direction on the $z=65$ mm side indicating that there must be a spanwise velocity directed from $z=15$ to 65 mm. For the lower region the flow rate is highest along the $z=15$ mm side, resulting in the earlier reattachment on this surface, indicating that there is a spanwise velocity directed from $z=65$ to 15 mm. According to Abbott and Kline, immediately after a step there is a three-dimensional zone of separation characterized by two, or more, vortices counter rotating about axes normal to the channel floor. It seems that the modest aspect ratio (5.33) in the current study has resulted in these two corner vortices being forced together resulting in destructive interference of the two to produce a

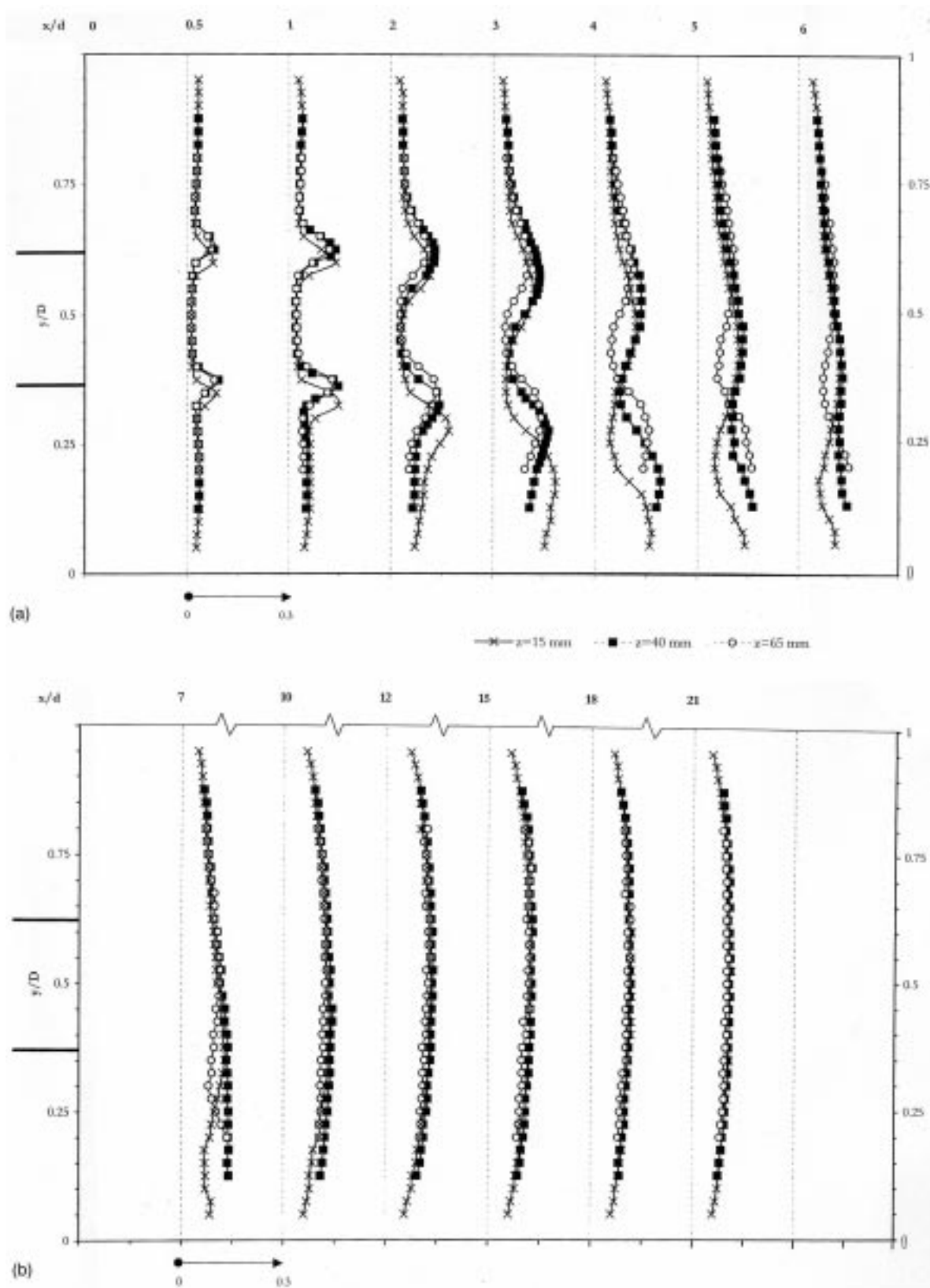

FIG. 10. (a) and (b) rms transverse turbulence intensity profiles (v'/U_B).

clockwise vortex on the lower wall and a counterclockwise vortex on the upper wall. We suggest it is this mechanism which causes the asymmetry about the XY center plane. To investigate this hypothesis the spanwise variation of the

mean axial velocity component was measured at various transverse heights at $x/d=2$, the location of maximum flow rate deviation in the centerplane (Fig. 4). In the near-wall region ($y/D < 0.2$) of the lower recirculation region shown in

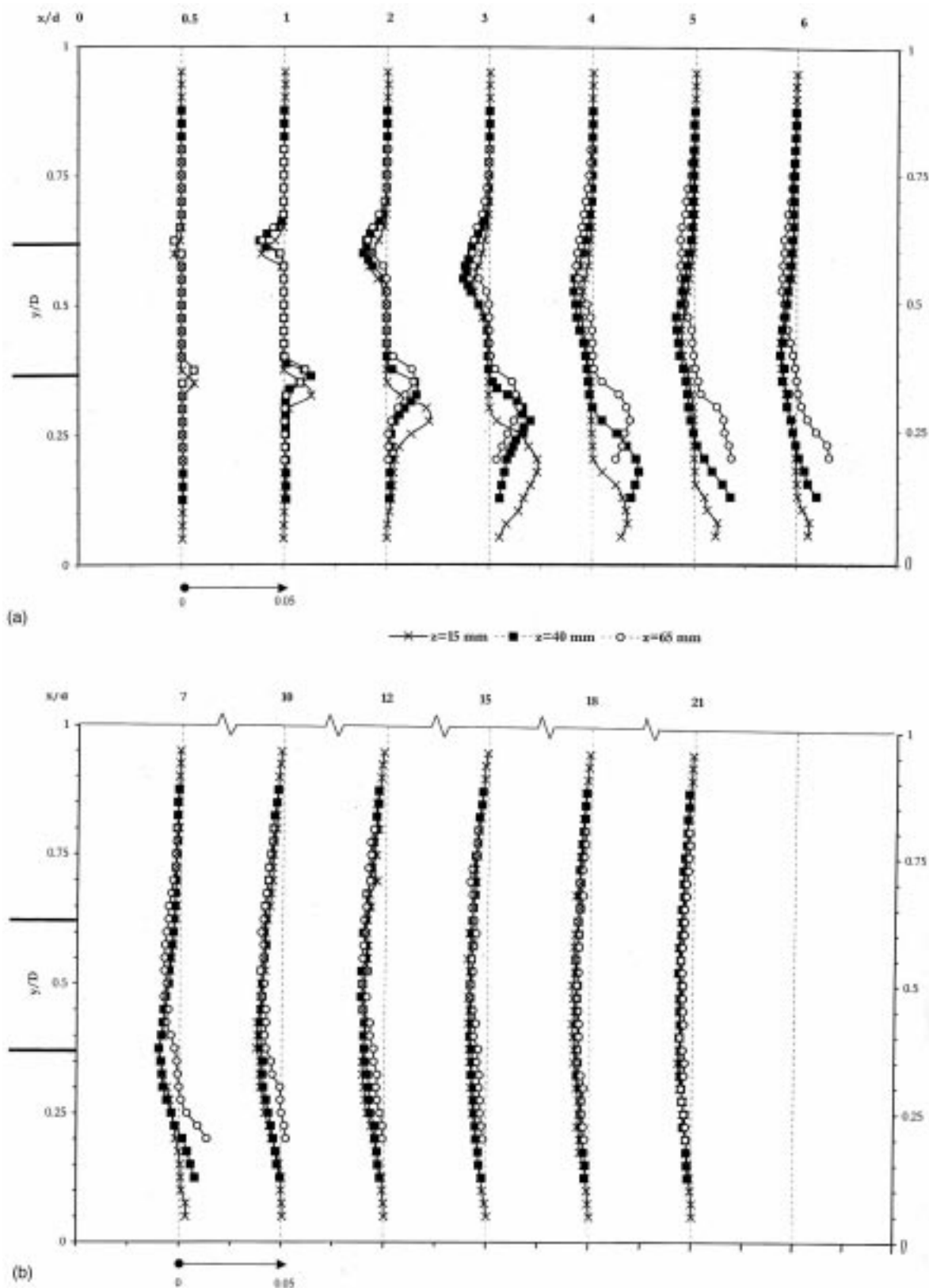

FIG. 11. (a) and (b) Reynolds shear stress profiles ($-\overline{uv}/U_B^2$).

Fig. 6(a) all velocities are low in magnitude ($<0.2U_B$), negative, and the flow is approximately two-dimensional as is the case in the high velocity core ($0.4 < y/D < 0.5, U/U_B \approx 0.95U_B$). However, for the shear layer in between, the

flow is strongly skewed with higher velocities occurring on the near side of the expansion ($0.2 < z/w < 0.4$) and a gradual decrease for $z/w \rightarrow 1$. The flow in the upper part of the duct is considerably more complicated, with the flow being strongly

skewed not only within the shear layer but also on the far side of the duct ($z/w > 0.75$) where the flow changes from the negative to the positive streamwise direction, as was observed previously [Fig. 3(a)]. Also, the spanwise asymmetry is in the opposite sense to the lower region with increased velocities on the far side of the duct.

A numerical simulation of the experimental arrangement was performed using the standard $k-\epsilon$ turbulence model. Both a two-dimensional and a quasi-three-dimensional version of the code, which took into account the sidewall boundary layers, were employed. The two sets of calculations were in good agreement (reattachment lengths agreeing to within 5%) with the XY center plane data (i.e., $z = 40$ mm) and each other, the three-dimensional version resulting in symmetry about the XY center plane. This apparent agreement highlights the danger of concluding that because a two-dimensional calculation is in good agreement with center plane measurements the flow is necessarily two dimensional. The failure of the simulation to reproduce the spanwise asymmetry could be a problem inherent to the underlying isotropic assumption of the standard $k-\epsilon$ turbulence model. An alternative explanation for the failure could be that the symmetric flow is a valid but unstable solution to the Navier–Stokes equations, however modeled. An unsteady DNS or LES calculation, and perhaps even an unsteady RANS calculation, would reveal whether the modeled equations yield a stable symmetric flow. A strongly asymmetric flow generated in a symmetric geometry represents a major challenge to the CFD community.

C. Mean transverse velocity profiles, V/U_B

The mean transverse velocity profiles $V(y)$ (i.e., velocities in the y direction shown in Fig. 1) of Figs. 7(a) and 7(b) again reveal the lack of two dimensionality across the duct. Well downstream of reattachment, $x/d > 10$, the differences in V are slight with maximum values at most $0.04U_B$. Upstream of reattachment the differences in the lower region are due, as was the case with the axial velocity, to the different trajectories of the location of the mean axial velocity maximum of each of the profiles. The maximum negative transverse velocities in this region are roughly equal for $z = 15$ and 40 mm at about $0.3U_B$, but the more central trajectory of the $z = 65$ mm profiles results in a lower value of about $0.18U_B$. The downstream locations of maximum negative transverse velocities are in the sequence $z = 15, 40,$ and 65 mm which corresponds directly to the magnitudes of the reattachment lengths, i.e., the earlier maximum negative values are associated with earlier reattachment. In the upper recirculation region, $y/d > 0.625$, all the transverse velocities are of the same order ($< 0.05U_B$) and much smaller than those present in the lower recirculation region.

D. Axial turbulence intensity, u'/U_B

Figures 8(a) and 8(b) show the normalized rms axial turbulence intensity u' with the low (circa 3%) level at $x/d = 0$ being a direct consequence of the smooth contraction immediately upstream of the expansion. The asymmetry of the flow leads to the shear layers having different maximum

values for the turbulence intensity and for these maxima to be located at different downstream locations. In the lower recirculation region the maxima follow the trajectory of the high velocity core towards the lower wall. In the upper half of the duct, the location of the local maximum moved towards and then below the XZ center plane, where the region of high turbulence intensity increases with shear layer growth. By $x/d = 10$ the upper and lower shear layers have merged and there is only one maximum value, located at approximately $y/D = 0.5$.

As shown in Fig. 9, when the axial distance is normalized by the lower reattachment length, in the lower half of the duct all three profiles have approximately the same maximum u'_{MAX}/U_B value of 22–23%. After reattachment the u'_{MAX}/U_B values decrease rapidly as is also found in backward-facing step flows (see Eaton and Johnston). In the upper half of the duct the data again collapse quite well, when the axial distance is again normalized by the lower reattachment length, showing an increase in intensity until reaching a maximum about one inlet height on either side of the corresponding reattachment location. The $z = 15$ and 40 mm profiles have slightly higher values of maximum intensity in the upper recirculation region, 25–26%, compared to the lower. The $z = 65$ mm profile, with its more central trajectory and shear layers of similar thickness, has roughly equal maxima in both.

E. Transverse turbulence intensity, v'/U_B

The profiles of normalized rms transverse turbulence intensity v' shown in Figs. 10(a) and 10(b) are very similar in shape to those of the axial turbulence intensity but have consistently lower maximum intensities. Only in the low turbulence intensity core, between the two shear layers, is the turbulence practically isotropic. At all other locations v' is always lower than u' . This anisotropy is especially pronounced in the upper recirculation region where the peak values are significantly lower than their axial counterparts: 14% compared with 26%. Even at $x/d = 21$ the turbulence is still anisotropic: the measurements show $u'/v' \approx 1.33$ at the XZ center plane.

F. Reynolds shear stress, \overline{uv}/U_B^2

The distributions of the normalized Reynolds shear stress \overline{uv} are shown in Figs. 11(a) and 11(b). Initially the three profiles at $z = 15, 40,$ and 65 mm are very similar in shape but the $z = 15$ mm profile is shifted down towards the lower wall. By $x/d = 3$, the $z = 40$ and 65 mm profiles have drifted apart, with the $z = 40$ mm profile peak value below the $z = 65$ mm profile, again in accordance with the differing reattachment lengths (see Table II). In the lower separation region the shear stress increases to a maximum, $-\overline{uv}_{MAX} = 0.023U_B^2$, at the edge of the recirculation zone with the peak occurring at the same axial location as the peak axial turbulence intensity. In the upper recirculation region the maximum occurred immediately after the step with a value roughly half that in the lower recirculation region, approximately $0.011U_B^2$. The peak of maximum shear stress de-

creases with downstream distance until at $x/d=21$ the profile is almost symmetric with a gradual increase from zero at the wall to about $-0.006U_B^2$ on the XZ center plane.

IV. CONCLUSIONS

Mean axial and transverse velocities, axial and transverse turbulence intensities, the Reynolds shear stress together with the wall pressure variation have been reported for a plane sudden expansion, of expansion ratio 4 and aspect ratio 5.33, at three spanwise and 13 axial locations.

In agreement with previous studies, the flow pattern downstream of the expansion was found to be asymmetric about the XZ center plane. Significant departures from two dimensionality were also observed about the XY center plane of the duct. It is suggested that the modest aspect ratio resulted in the two corner vortices formed just downstream of the expansion inlet being forced close together leading to the destructive interference of the two and it is this mechanism which caused the flow to be asymmetric about the XY center plane.

The maximum axial turbulence intensity occurred in the upper recirculation region with values as high as 26% of the bulk velocity at inlet while the maximum transverse intensity at this location was only 14%. Such strong anisotropy of the Reynolds normal stresses was not present in the lower recirculation region where the intensities were roughly equal at about 20%. The maximum Reynolds shear stress $-uv/U_B^2$ measured was approximately 0.023 and this occurred in the lower recirculation region.

At $x/d=21$ the flow had become essentially two dimensional across the duct but was still asymmetrical about the XZ center plane showing that the flow had still not recovered from the effect of the inlet expansion.

In spite of good agreement between two-dimensional and three-dimensional $k-\epsilon$ calculations and the XY center plane measurements, to capture the full three dimensionality of the flow field represents a significant challenge to the CFD community.

- ¹D. E. Abbott and S. J. Kline, "Experimental investigation of subsonic turbulent flow over single and double backward facing steps," *J. Basic Eng.* **84**, 317 (1962).
- ²N. K. Tutu and R. Chevray, "Cross-wire anemometry in high-intensity turbulence," *J. Fluid Mech.* **74**, 785 (1975).
- ³J. K. Eaton and J. P. Johnston, "A review of research on subsonic turbulent flow reattachment," *AIAA J.* **19**, 1093 (1981).
- ⁴R. Smyth, "Turbulent flow over a plane sudden expansion," *J. Fluids Eng.* **101**, 348 (1979).
- ⁵K. Szymocha, "An experimental analysis of the turbulent flow downstream of a plane sudden expansion," *Arch. Mech.* **36**, 705 (1984).
- ⁶A. Restivo and J. H. Whitelaw, "Turbulence characteristics of the flow downstream of a symmetric plane sudden expansion," *J. Fluids Eng.* **100**, 308 (1978).
- ⁷P. R. Mehta, "Separated flow through large sudden expansions," *J. Hydraul. Div., Am. Soc. Civ. Eng.* **107**, 451 (1981).
- ⁸F. Alouri and M. Souhar, "Experimental study of turbulent asymmetric flow in a flat duct symmetric sudden expansion," *J. Fluids Eng.* **122**, 174 (2000).
- ⁹Y. Gagnon, A. Giovanninni, and P. Hebrard, "Numerical simulation and physical analysis of high Reynolds number recirculating flows behind sudden expansions," *Phys. Fluids A* **5**, 2377 (1993).
- ¹⁰S. R. N. De Zilwa, L. Khezzar, and J. H. Whitelaw, "Flows through plane sudden-expansions," *Int. J. Numer. Methods Fluids* **32**, 313 (2000).
- ¹¹V. de Brederode and P. Bradshaw, "Three-dimensional flow in nominally two-dimensional separation bubbles; I. Flow behind a rearward facing step," *Aero Report 72-19*, Imperial College of Science and Technology, London, England, 1972.
- ¹²G. Papadopoulos and M. V. Otugen, "Separating and reattaching flow structure in a suddenly expanding rectangular duct," *J. Fluids Eng.* **117**, 17 (1995).
- ¹³M. P. Escudier and S. Smith, "Fully developed turbulent flow of non-Newtonian liquids through a square duct," *Proc. R. Soc. London, Ser. A* **457**, 911 (2001).
- ¹⁴C. Tropea, "Laser Doppler anemometry: recent developments and future challenges," *Meas. Sci. Technol.* **6**, 605 (1995).
- ¹⁵W. J. Yanta and R. A. Smith, "Measurements of turbulence-transport properties with a laser-Doppler velocimeter," *11th Aerospace Science Meeting* (Washington, AIAA paper 73, 1978), p. 169.
- ¹⁶K. B. Chun and H. J. Sung, "Control of turbulent separated flow over a backward-facing step by local forcing," *Exp. Fluids* **21**, 417 (1996).
- ¹⁷P. G. Spazzini, G. Iuso, M. Onorato, N. Zurlo, and G. M. Di Cicca, "Unsteady behavior of back-facing step flow," *Exp. Fluids* **30**, 551 (2001).
- ¹⁸J. Tihon, J. Legrand, and P. Legentilhomme, "Near-wall investigation of backward-facing step flows," *Exp. Fluids* **31**, 484 (2001).