

# **The need for a Second Solar-Digital Revolution**

## **Advice and warning from a friendly, alien civilisation**

As communicated to Dr David Hookes,

Department of Computer Science, Liverpool University, UK

Given at the International Congress on Globalistics, Moscow, 25-28 September, 2017

Greetings! - Inhabitants of planet Earth. We have been watching your planet from time to time over many centuries, sometimes with amusement, occasionally with pleasure, but mostly, with great concern, and, recently, with increasing despair, especially in the last few hundred years of your present socio-economic system. After your last 20<sup>th</sup> century of wars, including two 'world wars', as you call them, and many smaller wars that followed the end of the second of these world wars you appear to be still intent on self-destruction. According to our estimates these smaller wars, alone, have caused directly or indirectly a total of about 20 million deaths of your people. We do not include in this estimate the many millions of people who have died too early due to inadequate healthcare or food and water distribution. The latter appears to be due, in part, to the imposition of corrupt dictatorships on the poor countries by the rich countries.

Given the relatively advanced state of your scientific and technical development we are amazed that you have not yet worked out how to share the resource of your planet in an approximately equitable manner for all its inhabitants, including non-Homo sapiens species. We called this desirable state on our original planet, an Equitable Ecological Equilibrium State (EEES), from which a social-evolutionary process can advance further. We should inform you that we have observed other planets in your own galaxy that failed to work out how to achieve this desirable and essential state of affairs: they are now dead planets. In fact, in some cases, we did try to warn them but they ignored our warning.

### **WE ARE NOW WARNING YOU!**

We will now mention what we regard as critical factors that contribute to your apparent lack of awareness of the dangers of your current trajectory:

**The era of excessive consumption:** It seems, and we have observed this on many other planets, that when the capitalist socio-economic system reaches a level of excessive consumption the population gets locked into a work-consumption cycle from which it is very difficult to escape. We have observed that you have developed sophisticated advertising and propaganda systems that encouraged people to become self-absorbed, creating false wants through an understanding of the hidden emotional drives, below the surface of their consciousness. This understanding derived from the work of one of your major thinkers, a Dr Sigmund Freud [1], and carried into practice in the USA by his nephew, Edward Bernays[2].

**The suppression of science-based critical thinking:** This state of excessive consumption was also coupled with the ability of dominant social groups (the elites) to suppress science-based critical

thinking in the population as a whole, or, even better for them, prevent it from ever arising. Of course, such critical thinking has been allowed, even encouraged, amongst a relatively narrow sector, the scientific and technical intelligentsia. Such thinking is necessary so that they can produce innovative products for the market place and for the military, and also solve practical problems. These elites have used a combination of methods to achieve the aim of dumbing down the general population: the creation of a generally poor quality and increasingly expensive education systems combined with incessant propaganda from the private and state-owned media companies in favour of the status quo. For instance, nothing illustrates this lack of science-based critical thinking in certain sections of your population, than the fact that there is still a widespread absurdly unscientific idea that the band of light frequencies reflected from a person's skin has something to do with their quality as a human being.

**The creation of spectacles:** As has been pointed out by one of your most innovative thinkers, Mr Guy Debord [3], there is an increasing emphasis in your popular culture of creating spectacles of various sorts, for instances, in sports and other forms of entertainment. This helps to distract large sectors of the population from the real problems that confront them in their daily lives. It thus militates against the development of critical thinking and a planetary consciousness. If one can vicariously over-identify with a team of sport players or a popular music group or an individual film star, then it may be difficult to identify with the solution of real problems confronting your species.

**The role of fundamentalist religions:** In addition, we note that you are still battling against various fundamentalist religious groups which appear to reject a rational, scientific approach to understanding your own origins and your relationship with the rest of nature. For example, we observe, that one group, called the Christian Evangelicals, who constitutes a significant fraction, about 40%, of the population in the most economically and scientifically advanced country, the USA, actually believe your planet earth is only 6,000 years old. Of course, if that were the case it would be necessary to close down all the geology departments in your universities, since they insist, correctly, we can assure you, that your planet earth is about 4.5 Billion years old. Amusingly, the closure of such departments would be resisted by fossil fuel companies, which rely on such a science to find new deposits of fossilised energy sources. This is truly ironic since certain individual owners of fossil fuel companies, for instance, the Koch brothers, help fund these backward anti-scientific fundamentalist groups. Of course, funding irrationality may itself be rational, from a personal interest point of view.

### **Aspects of our own background:**

Our civilisation is several 100,000s of years older than yours, and, as you may have guessed, we did manage to make a transition to an equitable ecological equilibrium state (EEES) with respect to the rest of the living systems on our original planet. We have long since moved to other planets in many galaxies using our mastery of the theory and practice of space-time delocalisation physics. This mastery was based on our advanced understanding of the holographic quantum-gravity information system. The latter includes the understanding of how quantum physics and matter itself arise from the fine structure of space-time. This process creates the matter in the universe by holographically projecting the information stored in the quantum fields at its boundary, to create particles, 'It-from-Bit' as your Prof. John Wheeler pithily described this possibility [4]. It is not possible to explain these laws in depth at your stage of development, although some of your most advanced physicists have

caught a glimpse of such physics. We also undertook the almost universal social-evolutionary route of developing a capital-based economic system which, as one of your key thinkers, a Dr Marx [5], pointed out, releases very powerful productive forces or techniques. This stage is, therefore, necessary in your development from tribal and then static feudal societies. However, we made our transition to the post-capitalist EEES socio-economic system after the initial phase of industrialism and, thus, before we reached the 'excessive consumption' stage of the capital system. We are aware that you made a catastrophic error of trying to go beyond capitalism in a society that had not yet even fully developed a capitalist socio-economic system itself, and was largely feudal, or in places, pre-feudal. This step was taken against the explicit advice of your most advanced thinker in the field of socio-economics, Dr Marx, while paradoxically claiming to be his disciples. I do not need to remind you of the immense human suffering caused by this disastrous mistake.

### **There is still hope if urgent action is taken:**

There are a few examples of planetary civilisations that did manage to reach an EEES, even after they had entered the excessive consumption stage. So all is not necessarily lost if you act with urgency.

**Switching from military technologies to technologies for sustainable development:** One way to the act with urgency required is to imagine that you are in military situation in which you are about to be attacked by a powerful enemy. You will recall this happened before the start of your Second World War when industrial production had to be switched rapidly to military hardware in some unprepared countries. But, in this case, the 'enemy' is your human-induced climate change brought about chiefly but not only by the burning of fossil fuels and the adoption of intensive industrial farming methods. You now need to do the opposite, to now switch from your present excessive military production to technologies for combatting climate change as well as for sustainable development, in general. We will shortly explain how we achieved this EEES, and were thus able to further evolve as a planetary society. You may be aware that evolutionary processes take place within an overall general but dynamical equilibrium state and only make a transition to a new equilibrium state at the end of an evolutionary development process- 'punctuated equilibrium' as your Prof Stephen Gould called it [ 6]. We believe that you may be on the brink of making this transition from the increasingly unstable socio-economic system of capital. Such transitions, throughout the history of the universe, are usually associated with the emergence of a new information system, as we shall discuss later.

### **A summary of the threats to your human civilisation:**

It appears to us that you are, at present, in the process of possibly creating a dead planet even though you have the scientific knowledge and technical expertise to prevent this. As some of your leading thinkers, for instance, Prof Chomsky, have been pointing out for some time now, there are **two major threats** to your continued existence as a living, evolving civilisation, as we see it.

**The threat of Nuclear War:** Firstly, you are continuing, at enormous cost, to renew your weapons of mass destructions, that is, nuclear weapons, many of which are on a hair-trigger alert. In fact, according to our observational records there have been about twenty near misses in which a full-scale nuclear war was narrowly averted [7]. This fact alone should have led you to the obvious conclusion that nuclear weapons constitute a very dangerous and unstable military system and

should be subject to a worldwide ban, as soon as possible. The, frankly, ludicrous argument that they have helped to 'keep the peace' is clearly contradicted by the 20m dead people mentioned above and therefore should be rejected forthwith. We should inform you that, in our observations across your galaxy we have not yet observed a planetary civilisation that survived the nuclear weapons era that did not abolish such weapons within a hundred years of their invention and most well before that. Some planetary civilisations, such as our own, made an early decision not to even begin their development. On this basis you should begin to abolish nuclear weapons from the armouries of your militaries immediately. And this can release resources to deal with your second major problem.

**The threat to the stability of the biosphere:** As already mentioned the second major cause of your imminent demise is your treatment of the biosphere and its ecology- it is frankly insane. You are continuing to create the conditions that will lead to runaway global warming within the climate system of the biosphere and thus the heat-death of the planet. The latter will cause the elimination of most species. In fact, we calculate, and many of your scientists agree with us, that you are in opening phase of your sixth mass extinction that may well exceed, in its destructive effect, your previous worst mass extinction, the Permian-Triassic extinction, about 206 Mya, in which up to 96% of all species died.

**Impending climate disaster:** It is your addiction to the burning of fossil fuels that is driving your impending climate disaster as your James Hansen has explained clearly [8]. It is as insane as you approach to nuclear weapons. We know of course that the origin and development your present socio- economic system of capital is closely linked to discovery, and subsequent use of fossil fuels, coal, oil and natural gas, at least in its industrial phase. We also passed through this phase of development. We therefore understand that there is a great deal of profit still to be made from this natural but limited resource. There is also a great deal of fixed capital invested in the fossil fuel energy industry and allied industries such as various forms of transport and infrastructure, such as road, rail, and air transport.

**The role of your main stream media (MSM):** We also observe that these fossil fuel corporations are **closely linked to the corporations that** control your main stream media (MSM). Take for example the board of the **New York Times**. It includes representatives of Merck, Morgan Guaranty Trust, Charter Oil, American Express, Bethlehem Steel, IBM, Scott Paper, Sun Oil, First Boston Corporation, Ford Motor Company and Manville Corporation. It is well-known that a leading MSM owner, a Mr Rupert Murdoch, was strongly in favour of your recent disastrous Iraq war because of the access to Iraq's oil that would result. He is also an investor in Genie energy which is attempting to steal the oil beneath the Golan Heights that belong to Syria. You should be aware that Mr Murdoch's media empire grew rapidly after he agreed to use it to promote the agenda of your planet's leading spy agency, the CIA.

You should also be aware that MSM have systematically lied to their readers, listeners, and watchers about the dangers of the continued burning of fossil fuel. Presumably, this is because they are thinking only of short term profits rather than the future of their children and grandchildren. We strongly recommend the book by two of your leading political writers, Prof Chomsky and a Dr Herman, called 'Manufacturing consent' [10] which gives a crystal clear account of how the media strongly influence your political choices.

**The poisoning of the biosphere:** There are many other aspects of your disastrous treatment of the biosphere, including the poisoning, of the water, land and the food system due your use of industrial farming methods. The introduction of GMOs in the food chain is especially dangerous as we discovered. These methods are leading to a massive loss of biodiversity. The industrial farming methods are also a major contributor, as much as 20-30%, to the greenhouse gas emissions. All planets that survive take the step of returning to a largely plant-based diet and adopt agroecological farming methods using solar energy to increase the productivity of the small farms. We found that it is possible to produce enough food with agroecological methods if about 10-15% of our population were involved principally in agriculture. As solar technology advanced the fraction of time needed to spend 'in the field' as it were was much reduced. The new ICT meant that a rural or semi-rural existence did not isolate people from participating in the cultural variety available in cities.

At a critical stage we found that it was necessary to confront what you call 'Big Pharma', that is, the cartel of a few very large pharmaceutical companies which benefited from the adverse health effects of industrialised farming and the burning of fossil fuel. We also realised that Big Oil, Big Pharma and Big Agribusiness had, in fact, an unholy alliance and had to be forcibly disbanded once the a science-based, critically thinking population realised this state of affairs. Big Oil supplied Big Agribusiness with feed stocks for the herbicides, pesticides and so on. The poisons thus introduced into the food system created the demand for drugs from Big Pharma which were calculated not to produce complete cures, but to ameliorate the bad health effects due to poisoned food system. They were keen not to reduce the number of customers by actually curing them. Of course, there are many unhealthy consequences of burning fossil fuels, themselves, which are too numerous to mention here.

### **The transition from fossil fuel to solar energy:**

A key step in our own socio-economic evolutionary development was the rapid transition away from fossil fuel to solar energy in all its forms, but especially the solar-photovoltaic form. [Figure 1] As your scientists have already told you there is at least 10,000 times more solar energy falling on your planet every year than you need for all your energy consumption in a year. We note that your very latest PV technology can convert sunlight at 40-45% efficiency using quantum-well technology [11]. However, you still need to develop the means to mass produce these photocells, a relatively straightforward problem compared to, say, capturing energy from thermonuclear processes created on your planet, itself, rather than those that power the sun itself, that is, what is called 'fusion power'. We are aware that your costs of installing a watt of solar PV is now less than that of fossil fuel [Figure 2]. We note that this massive drop in price has meant that even states in the USA that are centres of fossil fuel industry, such as Texas, are now switching to solar energy [Figure 3].

**The significance of binary Digital Systems (bDS) technologies:** A key component of our own move into the EEES age was the development of binary Digital Systems (bDS) technology, sometimes called by you, Information and Communications Technology (ICT). We also mean the digital technology for control of production systems and the digital sensor technology for monitoring these systems and their effects on the environment. For this reason, we prefer the more inclusive concept of 'binary Digital Systems' (bDS) technology, which includes ICT as one branch. We developed this technology, as you have done, a few decades before we developed solar PV. As in your case, it was developed initially in a military context (Figure 4), but we soon recognised its revolutionary

significance for our socio-economic system on our planet. As with your experience the technology developed rapidly over a few decades after the invention of integrated electronics so that digital processors many millions of times more powerful in processing speed of the first processors could be placed on an integrated circuit that fits comfortably in the palm of a hand [Figure 5]. The possibility of using this technology to integrate the various sources of solar energy on a planetary basis was a key insight. But we also realised that it could radically transform the control of almost all aspects of production in a relatively short time, eliminating unnecessary labour and thus increasing the time for cultural pursuits. [Figure 6]

**The bDS-based enlightenment:** We also realised that bDS was not only a revolution in control of the energy and its release in production and other processes it was also a revolution in communications which greatly enhanced cultural exchanges on a planetary basis - in fact it led to a what we called a Planetary Enlightenment. You will remember that you had an Enlightenment in your Eighteenth century, but that was limited, largely, to a relatively small elite who were literate. This Enlightenment was based on printing, the ICT of the first stage of the capital system. But the arrival of an immensely more powerful bDS-based ICT meant that there was a rapid development of a science-based critical thinking mentioned above amongst the broad masses of our people on our planet. For instance, it was possible to use bDS to create educational equipment to make fundamental scientific ideas more easily accessible. [One example is given in Figures 7a,b,c,d which shows a Physics—is-fun workstation, developed by one of your own educators [12], that correctly tests what you call Newton’s Laws of mechanics. Your schools still use single trolley experiment which is not, in fact, a test of Newton’s Laws.] This latter step of widespread development of critical thinking was crucial in making the vast majority of our population aware of the dangers of global warming and the need to replace fossil energy with solar energy. As you may have guessed this increased awareness of what was happening to the planetary system as a whole led to a major increase in political awareness. In fact there was a global movement to replace the fossil fuel-based capitalist system for a post- capitalist EEES. This followed after a vast global conversation that was initiated through changes in the education system in many countries. This large-scale increase in critical thinking enabled many other technical and scientific developments to be seen as necessary and possible. An example was solar energy–driven small farmer agroecological farming methods which led to the rapid collapse of industrial farming, that is, agribusiness.

## **The Second Solar-Digital Revolution (SDR2)**

In our history’s digital data archive this merging of solar energy with binary digital systems technologies is known as ‘The Second Solar-Digital Revolution’. In fact, the recognition that we were entering a SECOND Solar-digital revolutionary age was critical to our ability to continue to implement this revolution. We realised that it was, in a sense, the long term outcome of the FIRST Solar- Digital revolution, that is, the beginning of the relatively rapid evolution of complex Life itself. To understand the significance of the SDR2 you must see it in the context of the first solar digital revolution SDR1, that is, the origin and evolution of complex life:

**The First Solar-Digital revolution (SDR1 )- the origin of complex life:** This realisation that our own existence as a species was itself a result of a solar-digital revolution, convinced the overwhelming majority that SDR2 was the correct direction to take. We realised that the evolution of complex life itself required two components: an early development of digital molecular genetic

code [Figure 8] and a universally available supply of energy to drive the chemical reactions essential for life. That source of energy was, of course, the sunlight. The evolution of the intricate molecular apparatus that achieved this capture of energy and stored it as carbohydrates occurred in primitive prokaryote bacterial cells, called by you the cyanobacteria, [Figure 9] that is, the evolution of photosynthesis [Figure 10]. These bacteria were eventually incorporated into plant cells to form the chloroplasts organelles [Figure 9], by a process, called endosymbiosis proposed by one of your leading scientists, Lyn Margulis [13] and, fifty years earlier, by Boris Kozo-Polyansky [14]. Photosynthesis stored energy in the form of carbohydrates and also released oxygen, which later played an important role in respiration in animal cells, as well as creating the iron oxide ores important for your Iron Age, as well as the later Industrial Revolution

The quaternary digital code for life evolved before the capture of solar energy. Similarly the binary digital systems had appeared before the future dominant form of solar energy capture, that is, solar photovoltaic cells (PV) with acceptable efficiency, could be manufactured. It should be noted that the technology for your modern bDS is closely related to that of solar PV, that is, both are semiconductor electronic devices.

Life could only evolve across the planet when it had access to an energy source that was abundant and distributed everywhere. Prior to the first solar-digital revolution the energy sources used to power the earliest forms of life were localised, initially, in warm alkaline vents on the ocean floors, where life actually began<sup>1</sup>.

We noted the similarities between the first and second solar-digital revolutions: the importance of quantum effects in both in photosynthesis and in the later redox reactive pathways in the respiration apparatus in mitochondria, and in physical processes the solid state electronics that became the mainstay of bDS; the role of the digital code in controlling the release of energy and the control of production processes for both solar-digital revolutions; the variations produced by mutations in the genetic code and the selection, by adaptation to changes in the environment, for the evolution of living systems had parallels in the evolution of software for the bDS – controlled processes as well as in its application in the communications sphere. For instance the development of adaptive AI algorithms with feedback; so-called ‘genetic’ programs that learn to evolve the correct control strategies by trial and error; the close parallel between the electronic Digital-to-Analogue Converters in bDS (referred to as DACs) and the action of a Ribosome in cells [Figure 11]. The former

---

<sup>1</sup> The latter gave rise to proton gradients derived from hydrogen and carbon dioxide which provided this energy, with iron-sulphur minerals acting as catalysts. Olivine in earths mantel reacts with water to produce hydrogen gas dissolved in warm alkaline fluid containing magnesium hydroxides when this warm mixture reaches the cold ocean waters it reacts with salts and precipitates out into vents on the see floor. The precipitate forms a labyrinth of inter-connected micropores, with thin walls separating these pores. Thermophoresis then concentrates small organics created by lightning discharges on the early history of your planet in the pores. The thin walls allowed a pH difference to exist between the alkaline interior and the acidic exterior due to dissolved carbon dioxide. This created a proton gradient which, together with the catalytic properties of Fe-S minerals in the pore walls, supplied energy for the synthesis of the more complex organic polymers such as RNA and precursors of proteins, lipids and other molecules, essential to the emergence of cellular life forms.

convert digital data to a continuously variable analogue signals, and the latter also converts quaternary digital data, in the form of messenger RNA, to analogue proteins which can have a continuously variable shape and function.

You should also note that the genetic code of qDS is a universal code for all species of living organisms, including viruses. Similarly the binary digital code is common to all applications of bDS, whatever the physical system used to implement its Boolean logic and store its data.

**Simulation-a unique feature of bDS:** One feature of bDS technology that is not replicated from qDS molecular technology is its capacity to test out models via simulation, that is, the process of abstraction of essential feature of a system or process and the creation of a mathematical model within a computer. This process represents, in a sense, a fusing of the qDS in the form of an intelligent species, Homo sapiens in your case, with bDS. In fact bDS is itself also a long term creation of qDS (living system intelligence). This simulation feature of bDS systems greatly enhances and speeds up the process of both pure and applied research. This capacity therefore has a positive feedback improving the design and performance of bDS systems themselves, for instance, in improving the performance of the sub-components of bDS such as transistors. In scientific research and engineering it allows the design and testing of structures and processes to be carried with much greater facility. [see Figure 4 for simulation of the Lorenz cypher machine by the first computer]

**Modelling the socio-economic system:** An important aspect of SDR2 was that it allowed us to see how the socio-economic systems can be modelled, that is, as coupled matter-energy-information flows similar to those of natural living systems created under SDR1. The socio-economies of natural systems had evolved to be stable systems until the arrival of the first truly intelligent species, you, Homo sapiens. Your species has evolved, as we did, the socio-economics of Capital that now threatens all natural systems on your planet, as well as itself.

**Advantage of SDR2 for the post-capital economic system:** SDR2 will also mean the replacement of much human labour with automated, intelligent systems so that the classical capital value system based on human labour will thus fade away. SDR2 will also enhance the attraction of the cooperative mode of production, that is, make this the logical scientific choice. Maintaining a competitive, exploitative system will inhibit and restrict the potentialities of SDR2 and so must pass into history or as your Dr Marx pointed out “The social relations of capital act as a fetter on the productive forces created by the capital system” We understand that already on your planet there are more people employed in cooperative enterprises than are employed directly by large transnational companies.

**The symbiosis of SDR1 with SDR2** We realised it is important to locate the SDR2 in this historical context. This means one can realise that the capital system created the technology, often within state enterprises, that reproduces, on a higher plane, similar systems that made possible the emergence of complex life itself. But, and importantly, it allows the possibility of a synthesis or a symbiosis of the SDR1 with SDR2. The use of solar energy rather than fossil fuel will allow the continuation of life, that is, the prevention the poisoning of the planet and its eventual heat death. SDR2 will also mean that the close control of production using bDS means that dangers to the biosphere from production processes and other human behaviour can be monitored and thus eliminated.



**The socialisation of production and overcoming alienation:** We also realised that SDR2 implied the need for socialisation of production system: the distributed character of solar energy and bDS points to the possibility of social control of production on a planetary basis. We also realised, as your Dr Marx has pointed out 150 years ago, that it allows the overcoming of various forms of alienation that resulted from the capital system. For instance, there is the alienation of the producers from the products of their labour, so that every productive person can now understand consciously how her/his activity relates to the total system of planetary production. It also helps to overcome the alienation of a producer from the rest of nature. The understanding of our relationship with nature and how our activities affect the rest of the biosphere will also become universal. Finally, it helps overcome the alienation of each member of your species from each other – you can understand your mutual inter-dependence, that is, the social character of your being, through the continual sharing of knowledge and expertise that is possible after SDR2.

Binary Digital Systems technology also means that the activity of producers can be integrated together, that is, local regional, national and international planning of production can take place. This will allow the full power of the technology to be realised, to use the planetary resources most efficiently and sparingly, to avoid waste and enable maximum recycling of the scarce resources.

The bDS technology also means a reduction in hours necessary for work and increased leisure time. It will thus allow an enhancement of cultural exchange, access to highest levels of culture, from any place on the planet, even in work places. So the technology that reduces the hours for work also allows us to enhance our cultural participation and enjoyment. bDS is not only a revolution in the control of production processes but also a revolution in human communication. The latter will be necessary to implement and operate SDR2, and this means that SDR2 will be a self-accelerating revolution as happened with the first solar-digital system revolution-SDR1. The vast abundance and variety of life was possible once solar energy was coupled to a quaternary digital information system- the genetic code. It has already been shown by one of your own scientists that the optimal genetic code evolved as the one which leads to the greatest rate of change of structure hence the one that is most agile in adapting to environmental change and thus selected by evolution. Once solar energy had been captured through the evolution of photosynthesis, life could evolve rapidly as the oxygen content of the atmosphere increased.

**The advantages of the ‘two solar-digital revolutions’ approach:** There are a number of the advantages of taking the ‘two solar-digital revolutions’ approach to understanding your present situation. For instance, it links the need to go beyond the present fossil fuel–based capital system, to the development of a more appropriate socio-economic system of production, that is, a SDR2-based socialised system of production. It clearly explains the scientific basis for the need to end the fossil-fuelled capital system. It also links that to the social evolutionary processes that are required to produce a new stable planetary system of production that works, harmoniously, with the results of SDR1, that is, the biosphere.

**A synthesis of qDS and bDS:** You should consider SDR2 to produce a synthesis of both bDS and qDS. As your scientists know the discovery of the genetic code and the decoding of the human genome would not have been possible without the extensive use of computers, that is, bDS technology. The use of the data from genomic studies to improve healthcare and to monitor and repair the damage done to eco-systems by fossil capitalism is be vastly enhanced by bDS. Figure 12

shows the very powerful computer clusters you have built to accomplish these tasks for the analysis of medical data based on over 1000 human genomes. Both SDRs have, at their heart, an Information revolution that leads to the creation of technology that could capture solar energy and control its release to power a production system. In the SDR1 the molecular machinery for capturing this energy, that is, early photosynthesis was created by evolutionary adaptations through mutations of the quaternary digital code. The qDS also produced the molecular machinery (assemblies of proteins) for the controlled release of this captured energy.

### **A final warning:**

We have given an account of how we made a transition to our own socio-economic EEES on our original planet. However you should be aware that this was not pre-determined - many planets with civilisations did not make this transition. It required determined action by our species. A technology that has great potential to liberate your species is used in your present socio-economic system to restrict your cultural development and even destroy the future of your planetary home. You will have to struggle against the present abuse or misuse of the powerful bDS technologies you have created, some of which are listed below:

1. The ICT branch of bDS is at present used, in parallel with other media, to spread the concept of ever-increasing consumption, with no regard to the finite limit of resources, and with almost total disregard for the accumulation of poisons in the water, atmosphere, and the food chain, and the destabilisation of the climate system.
2. ICT is used to encourage mindless cultural activities such as the computer gaming culture which often involves the promotion of war and violence as 'natural' or even fun.
3. The decrease in human interaction due to pre-occupation with 'screens' is another negative aspect of this ICT-based popular culture.
4. The increasing automation of manufacture and office work through application of bDS means increasing precarious nature of work.
5. ICT is used to enhance the spread fear, paranoia, ignorance, and stupidity. For instance, the emergence of some recent populist politicians with highly degenerate characters illustrates this point perfectly.
6. The bDS in the hands of your military elites also means the facilitation of war. From an early stage the bDS technology development was funded by military-Industrial complex so as to develop more accurate and effective killing machines. Other civilian applications only followed later. Even your internet has its origins in a military project.
7. The bDS technology is also used to create highly speculative financial activities that are undermining your production system- that is, inter-alia, the creation of 'fictitious capital', as Dr Marx called it.

We realised that for life to survive on the planet the Second Solar-Digital Revolution must come to the aid of the First Revolution - the products of the First SDR, fossil fuel, if continued as a source of energy, will cause the collapse of the biosphere. In other words, the fossilised products of First Revolution, fossil fuel, will destroy its later living products. The capitalist mode of production will always seek to maximise profit which it identifies with using fossil fuel to drive the production system. This must end and another post-capital production system built rapidly based on sharing:

sharing of energy; sharing of knowledge; sharing of the products of labour; sharing the resources of the planet with other species in other words: An Equitable Ecological Equilibrium State – EEES.

Of course, you are still as a species a product of the First Solar-Digital revolution, almost all your sustenance is still derived from this source. It will require a rapid social evolution to overcome your present apparent intent to destroy your planetary home. So the purpose of this message to you is to help supply a scientific framework for the direction you must take in order to save your planet from the self-destructive effects of your present socio-economic system. Only if you can grasp the next step on the path of your social evolution, that is, by seeing how it relates to other major epochs, can you have the urgency and, yes, even the courage to oppose the social forces of death and destruction. The latter arise from desire of the dominant social classes to protect their privileges rather than to enter the sharing world which is your only future as a species. A tiny fraction of your Homo sapiens which profit from the present grossly inequitable system should be asked to forgo its excessive wealth and privileges and join with the vast majority of your species to create a sharing, equitable world.

**An Equitable, Ecological, Equilibrium State for your planet is possible!**

## **Another world is possible!**

References:

1. Freud, S. *The Unconscious* Penguin Modern Classics, 2005
2. Bernays, E. *Propaganda (1928)* Ig Publishing New York, 2005
3. Debord, G. *The Society of the Spectacle (1967)* Black and Red, London, 1977
4. Wheeler, J. *Geons, Black Holes and Quantum Foam: A Life in Physics*. New York: W.W. Norton & Company, 1998.
5. Marx, K. *The Manifesto of the Communist Party (1848)* Oxford University World Classics 1998
6. Gould, S.J. *Punctuated Equilibrium* Harvard University Press, 2007
7. <http://nuclearfiles.org/menu/key-issues/nuclear-weapons/issues/accidents/20-mishaps-maybe-caused-nuclear-war.htm>
8. Hansen, J. *Storms of my grandchildren* Bloomsbury Publishing, London, 2009
9. Hallam, A. and Wignall, P.B. *Mass extinctions and there aftermath* Oxford University Press, 1997
10. Chomsky, N. and Herman, E.S. *Manufacturing consent* Vintage, London, 1994
11. Barnham, K. *The Burning Answer: a user's guide to the solar revolution* Weidenfeld & Nicholson, London, 2014
12. Hookes, D. *Science education, new technology, and development: a physics-is-fun workstation for distance learning*. <http://pcwww.liv.ac.uk/~dhookes/SciDEV1.pdf>
13. Magulis, L. *Symbiotic Planet : A New Look at Evolution*, Basic Books, 1998
14. Kozo-Polyansky, B. *Symbiogenesis: A New Principle of Evolution (1924)* Harvard University Press, Cambridge, Massachusetts, 2010,

A photovoltaic cell generates electricity when irradiated by sunlight.

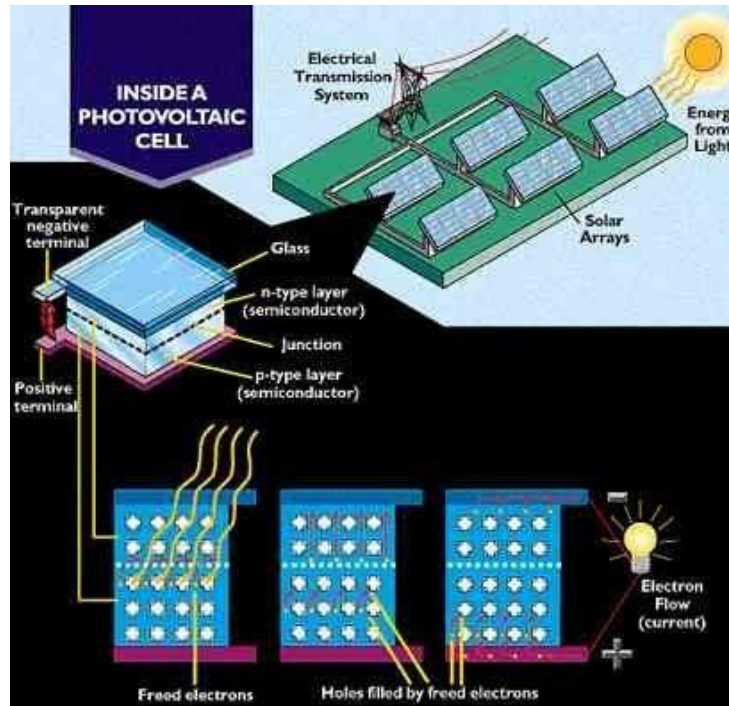
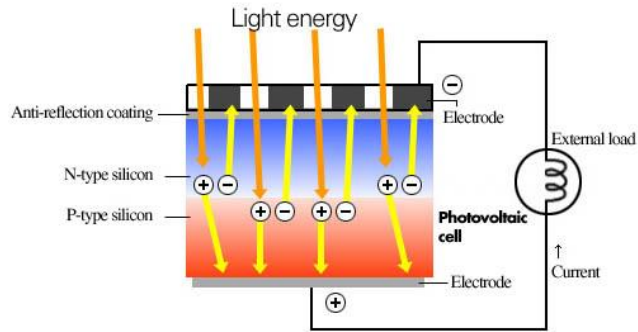

Figure 1: Solar Photovoltaic technology for the Second Solar-Digital Revolution

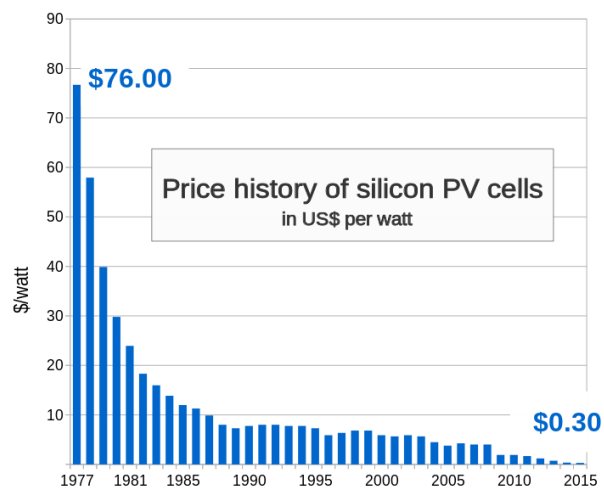

Figure 2: The falling price of Solar PV cells

Source: Bloomberg New Energy Finance & pv.energytrend.com

## Solar Energy for the second Solar-Digital Revolution



**Figure 3: A Solar Energy plant for Houston, Texas- HQ for US fossil fuel companies- with 204,000 solar panels, it supplies 10.5 % of city's electricity**



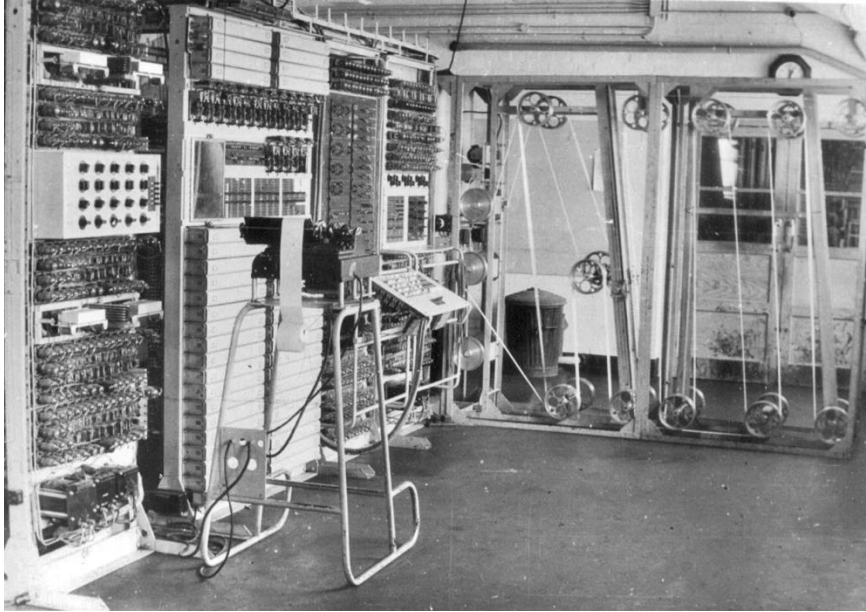

**Colossus**



**Lorenz** cypher machine

**Figure 4: Colossus** – the first electronic binary digital computer- it could simulate the Nazi **Lorenz** cypher machine, and thus decode its messages

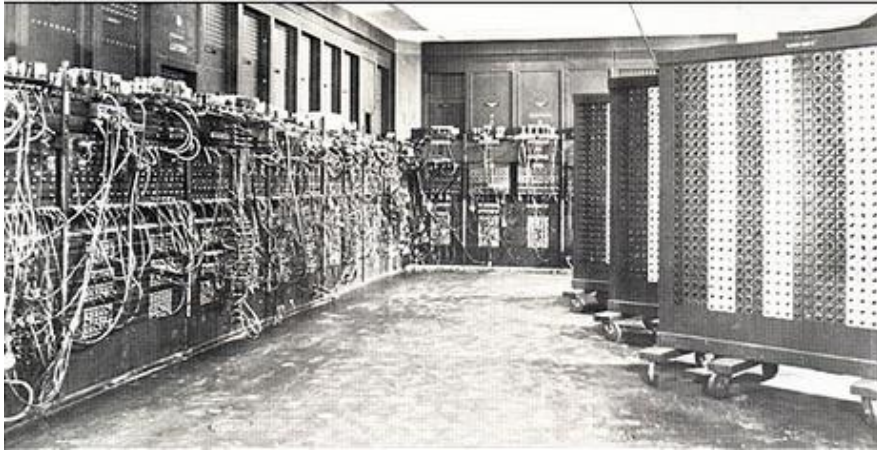

**First Generation:** with thermionic valves



**Second generation:** with single transistors

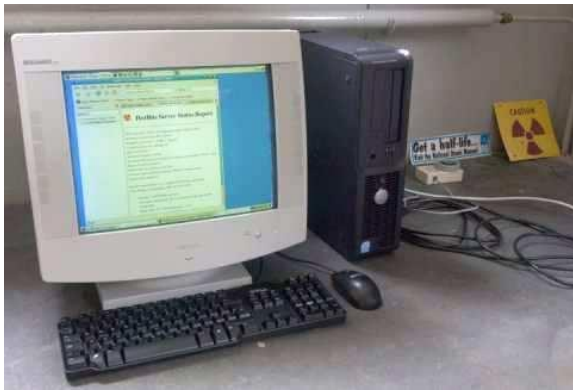

**Third Generation:** with microprocessors and highly integrated circuits



**Fourth generation:** mobile laptops



**Fifth Generation:** hand-held computer/phone

**Figure 5: Five generations of computers in 50 years**





Figure 6: A binary Digital Systems (bDS) industrial controller



# COMPUTRACK

## THE PHYSICS WORK STATION

COMPUTRACK LINKS THE MICRO COMPUTER TO  
INTERACTIVE EXPERIMENTS IN MANY AREAS  
OF PHYSICS TEACHING

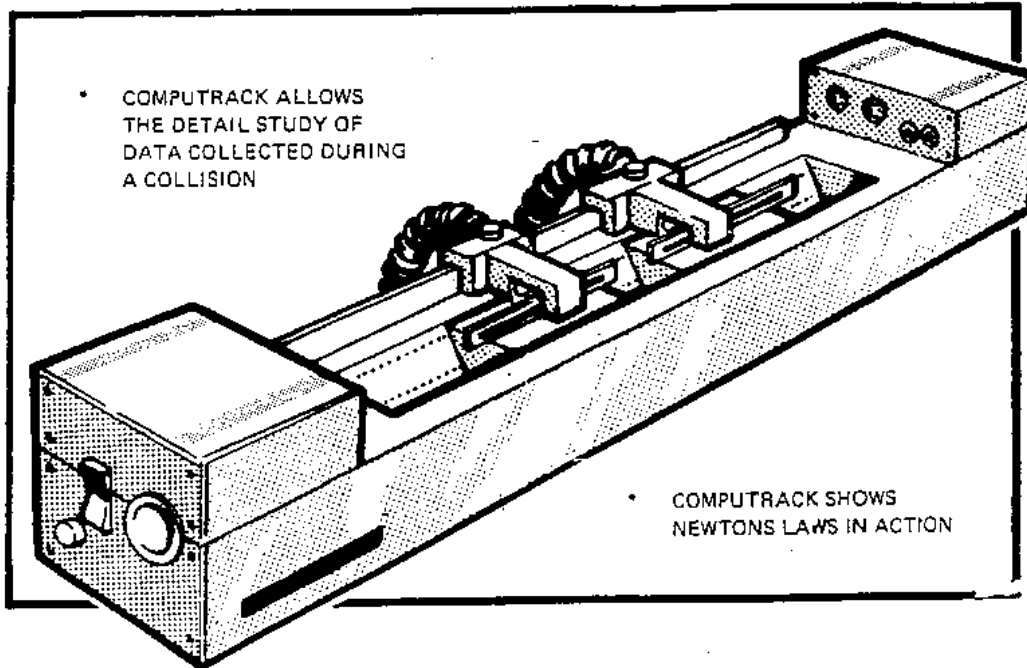

- COMPUTRACK ALLOWS THE STUDY OF ROTATIONAL DYNAMICS
- COMPUTRACK CAN BE EXPANDED TO INCLUDE EXPERIMENTS IN OPTICS, SOUND, ELECTROMAGNETISM, ELASTICITY
- COMPUTRACK PROVIDES FOR COMPUTER LINKED EXPERIMENTS IN MICRO ELECTRONICS
- MODEL AVAILABLE TO CONVERT EXISTING AIR TRACKS TO MANY OF THESE AREAS

**Figure 7a The Physics-is-Fun workstation**

# The Physics Workstation

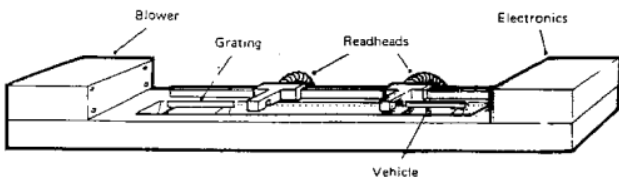
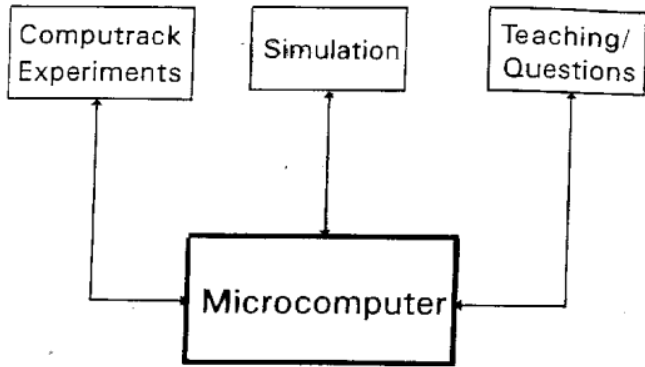

The principle of the Slit-source, Grating and Photocell method (SGP)

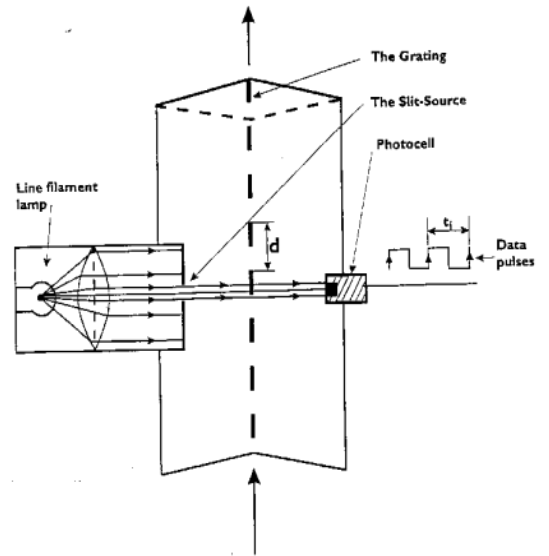

$$v_i = \frac{d}{t_i}$$

$v_i$  - the average velocity for  $t_i$

$$Tv_i = \sum_{j=1}^{i-1} t_j + \frac{1}{2} t_i$$

$Tv_i$  - the total time to the middle of  $t_i$

$$s_i = \sum_{j=1}^i d_j$$

$s_i$  - the total displacement up to  $d$

$$Ts_i = \sum_{j=1}^i t_j$$

$v_i, Tv_i$  Are the coordinates for v-t curve  
 $s_i, Ts_i$  Are the coordinates for s-t curve

Figure 7b: Digital instrumentation for the Physics-is-Fun Workstation

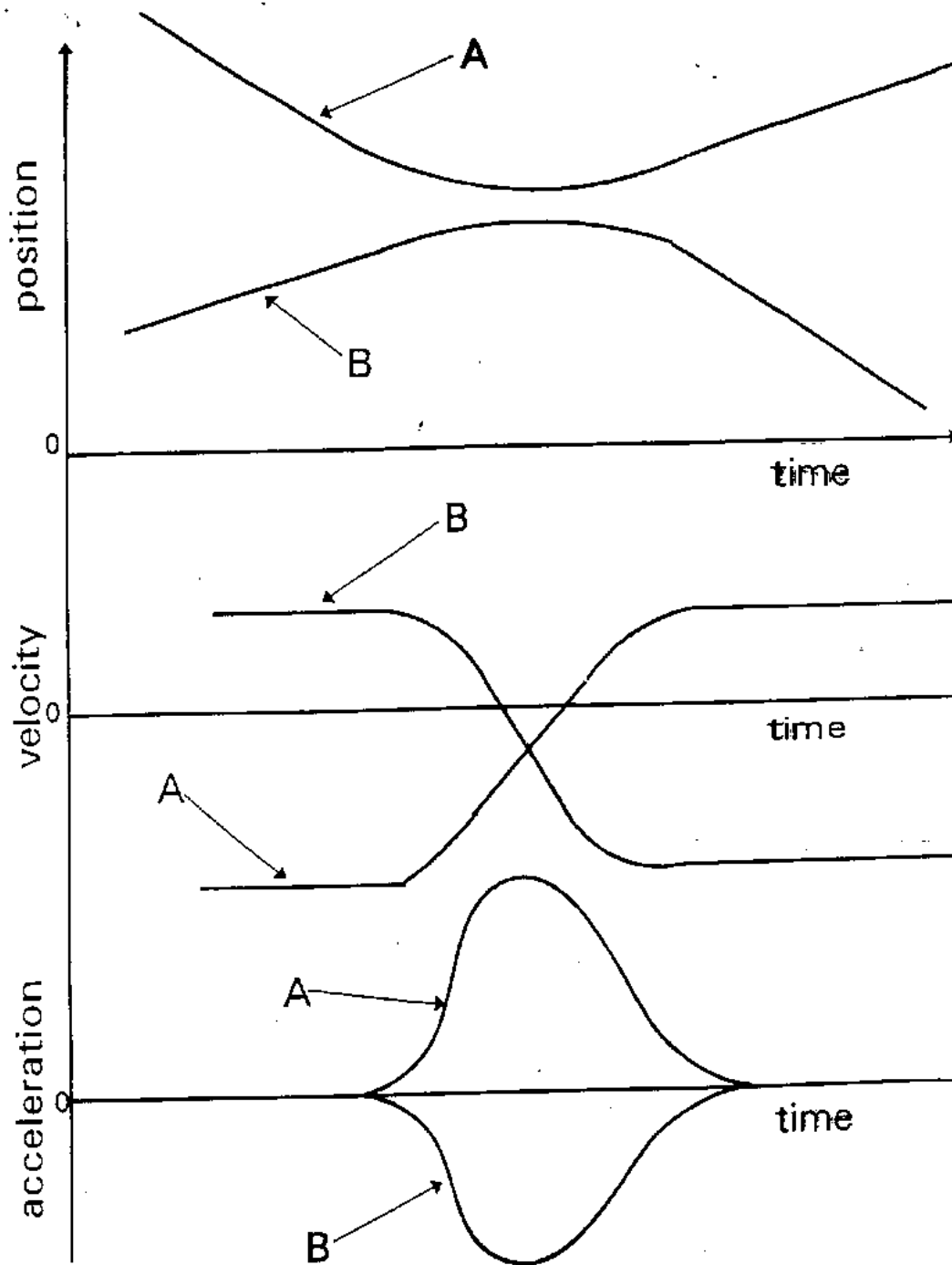

**Figure 7c:** Position-, velocity-, acceleration- time output graphs from the workstation for a two-vehicle elastic collision

## Testing Newton's Laws

Bodies A and B interact with accelerations  $a_{AB}$  and  $a_{BA}$



Similarly A and B interact separately with reference body C

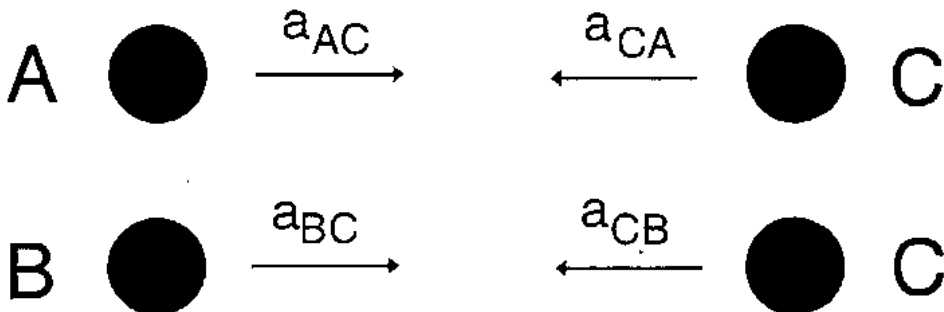

Experimentally it is found that the ratio of accelerations for each pair of bodies is constant at all times during the interaction, that is:-

$$-\frac{a_{AB}}{a_{BA}} = K_{BA} \quad -\frac{a_{AC}}{a_{CA}} = K_{CA} \quad -\frac{a_{BC}}{a_{CB}} = K_{CB}$$

It can also be shown experimentally that these constants are related as follows

$$K_{BA} = \frac{K_{CB}}{K_{CA}} \quad \text{Therefore: } K_{CA} a_{AB} = -K_{CB} a_{BA}$$

Choose  $m_A = K_{CA}$  and  $m_B = K_{CB}$  called the masses of A and B relative to reference body C

Therefore:  $m_A a_{AB} = -m_B a_{BA}$  that is, Newton's Laws

**Figure 7d:** Correctly testing Newton's laws with the Physics-is-fun workstation

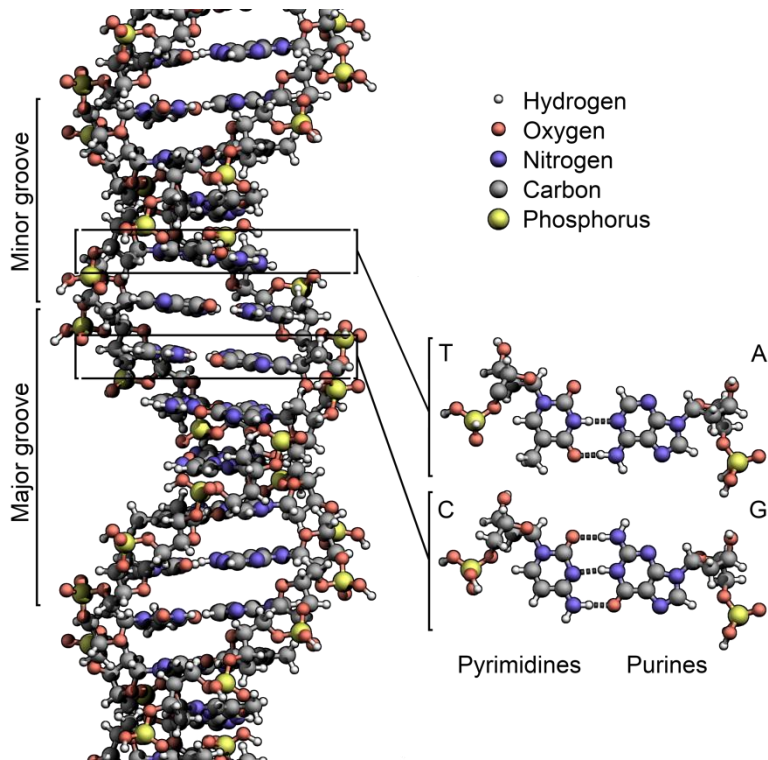

**Figure 8a: the Molecular structure of the DNA double helix for the qDS genetic coding**

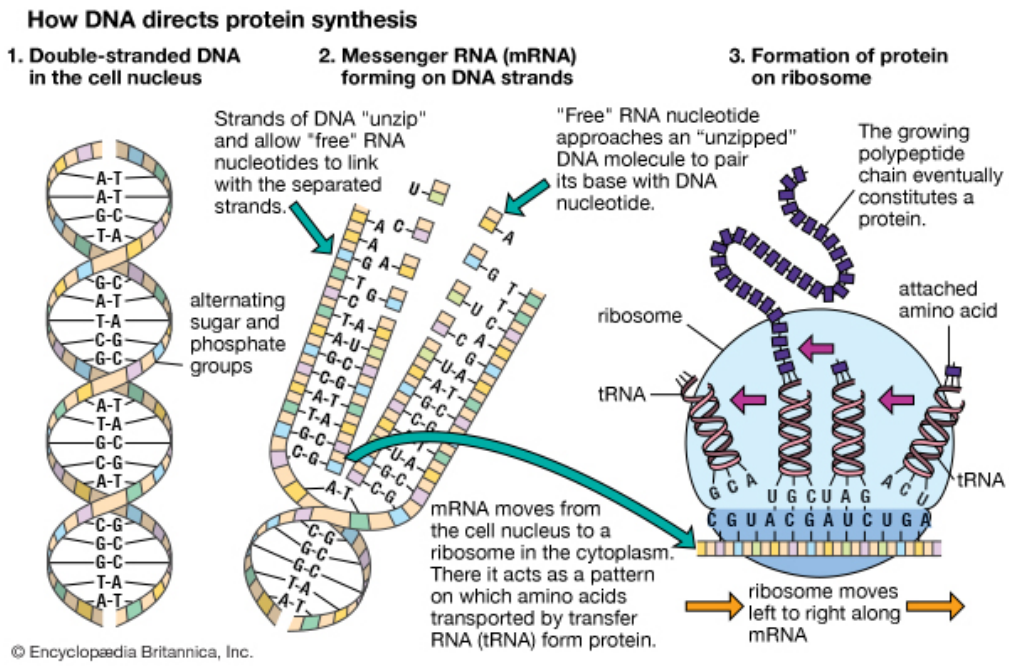

**Figure 8b : The role of DNA, messenger-RNA and transfer-RNA in protein synthesis for the quaternary Digital System(qDS) of the molecular genetic code**

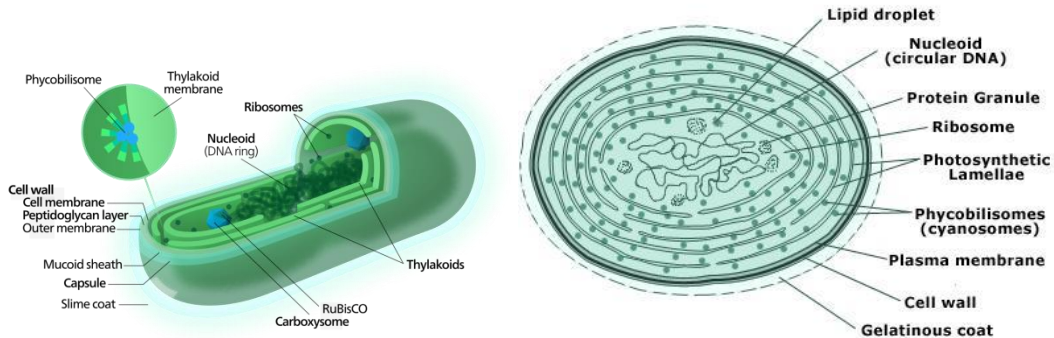

**Diagrams for a typical Cyanobacterium cell**

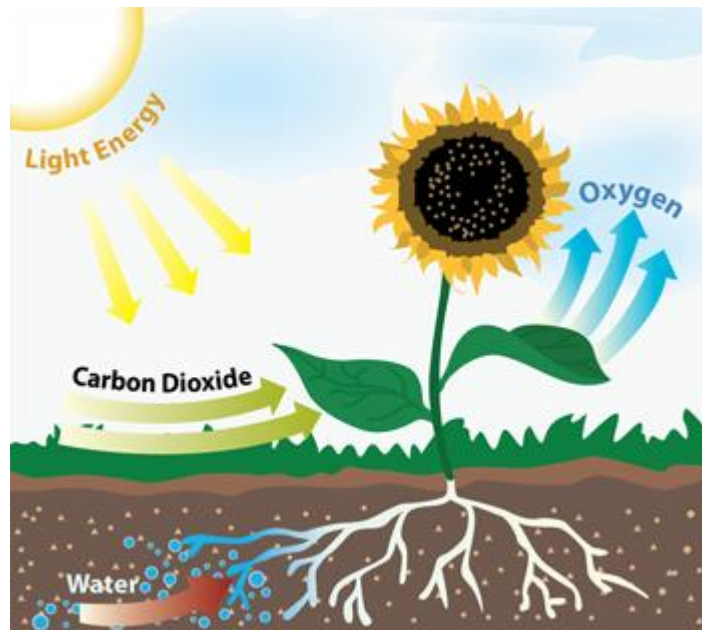
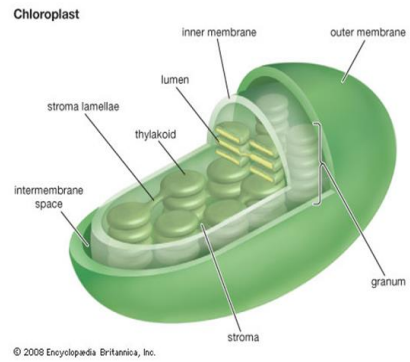
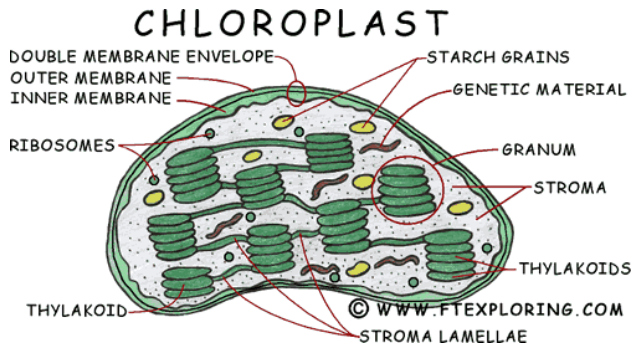

**Figure 9** Cyanobacteria and Chloroplasts for Solar Energy capture for the First Solar-digital revolution

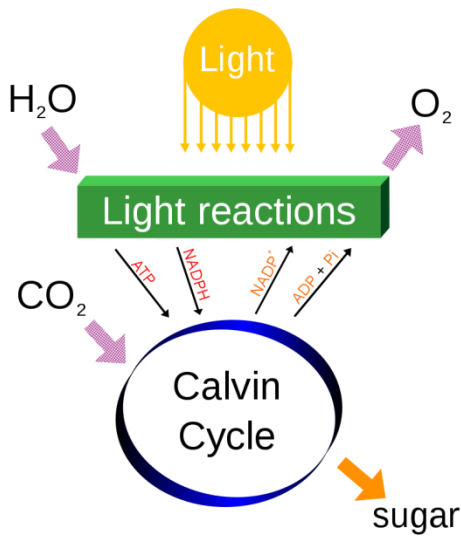
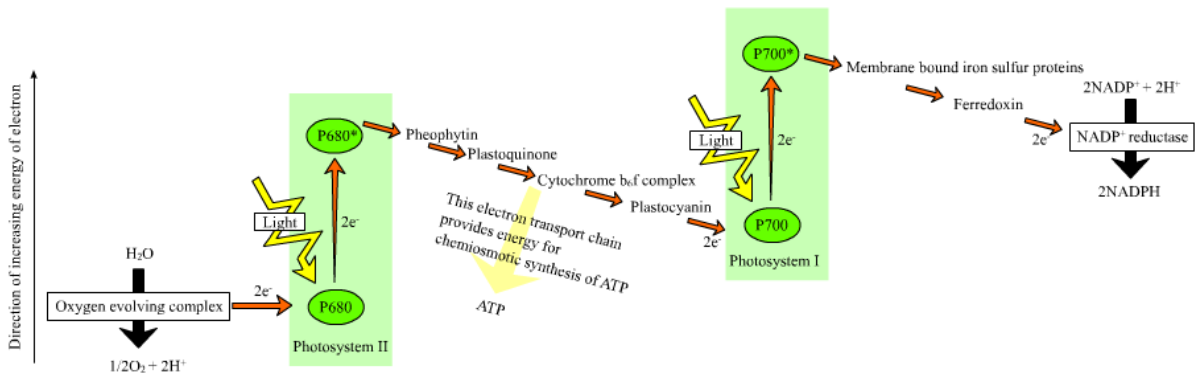
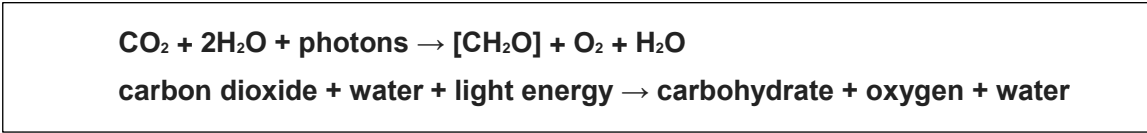
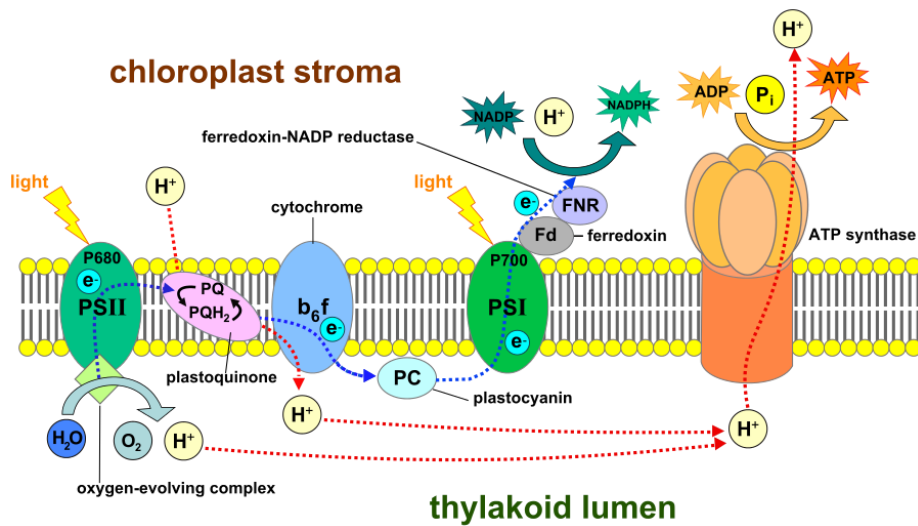

**Figure 10** The complex chemistry of Photosynthesis



**Protein analogue output**

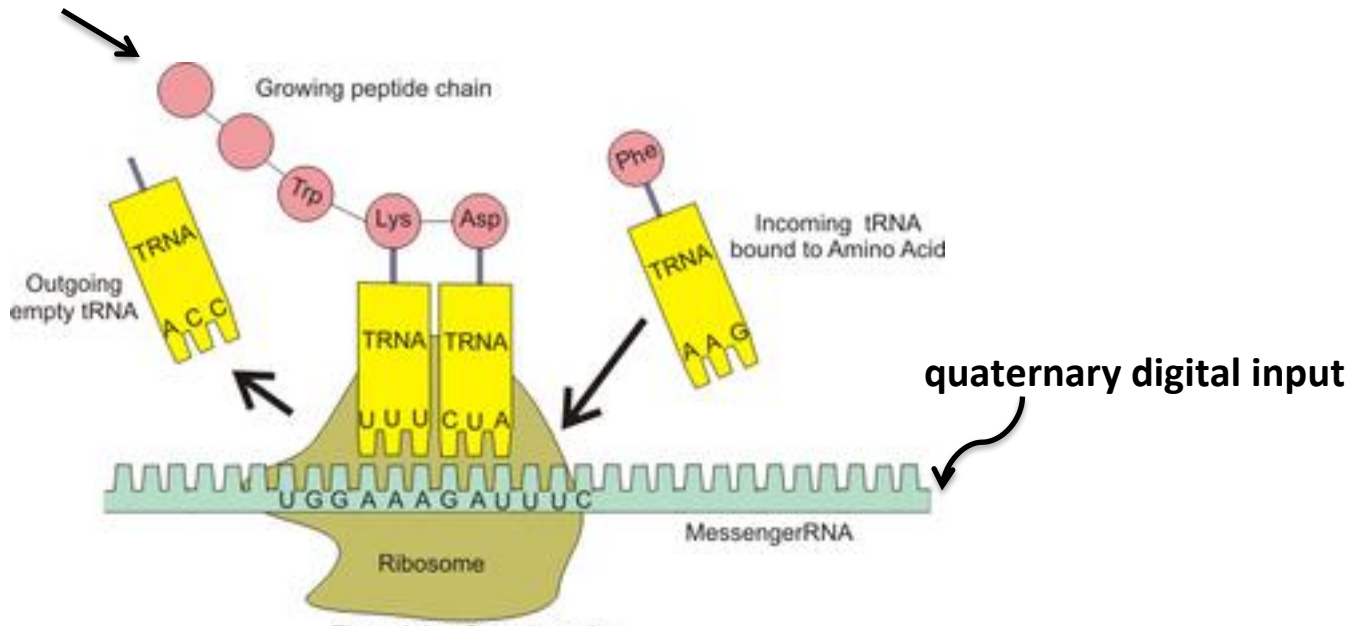

**The Ribosome**

**Figure 11a:** The quaternary Digital-to-Analogue Converter (qDAC):  
for the first Solar-Digital Revolution

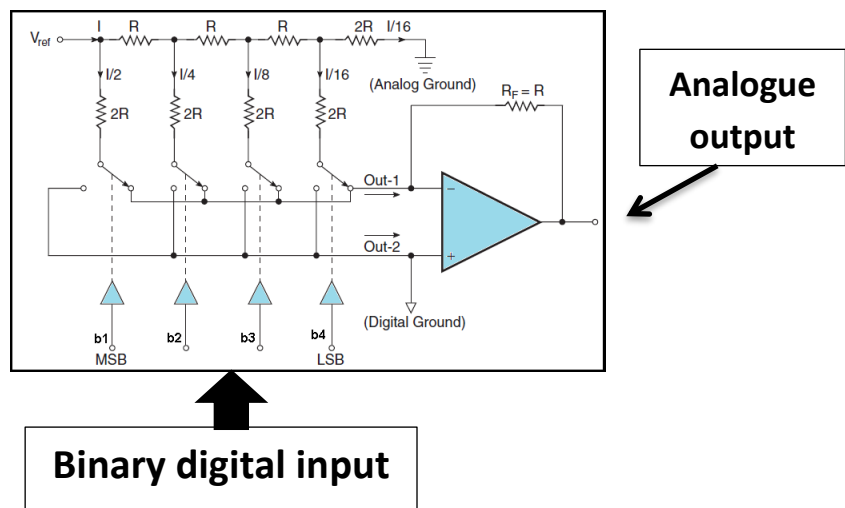
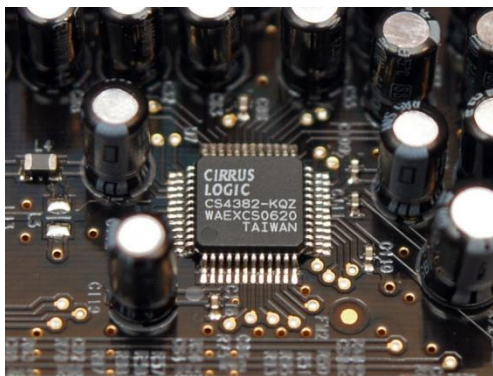

**Figure 11b** A binary Digital-to-Analogue Converter (bDAC)  
for the second Solar-Digital Revolution



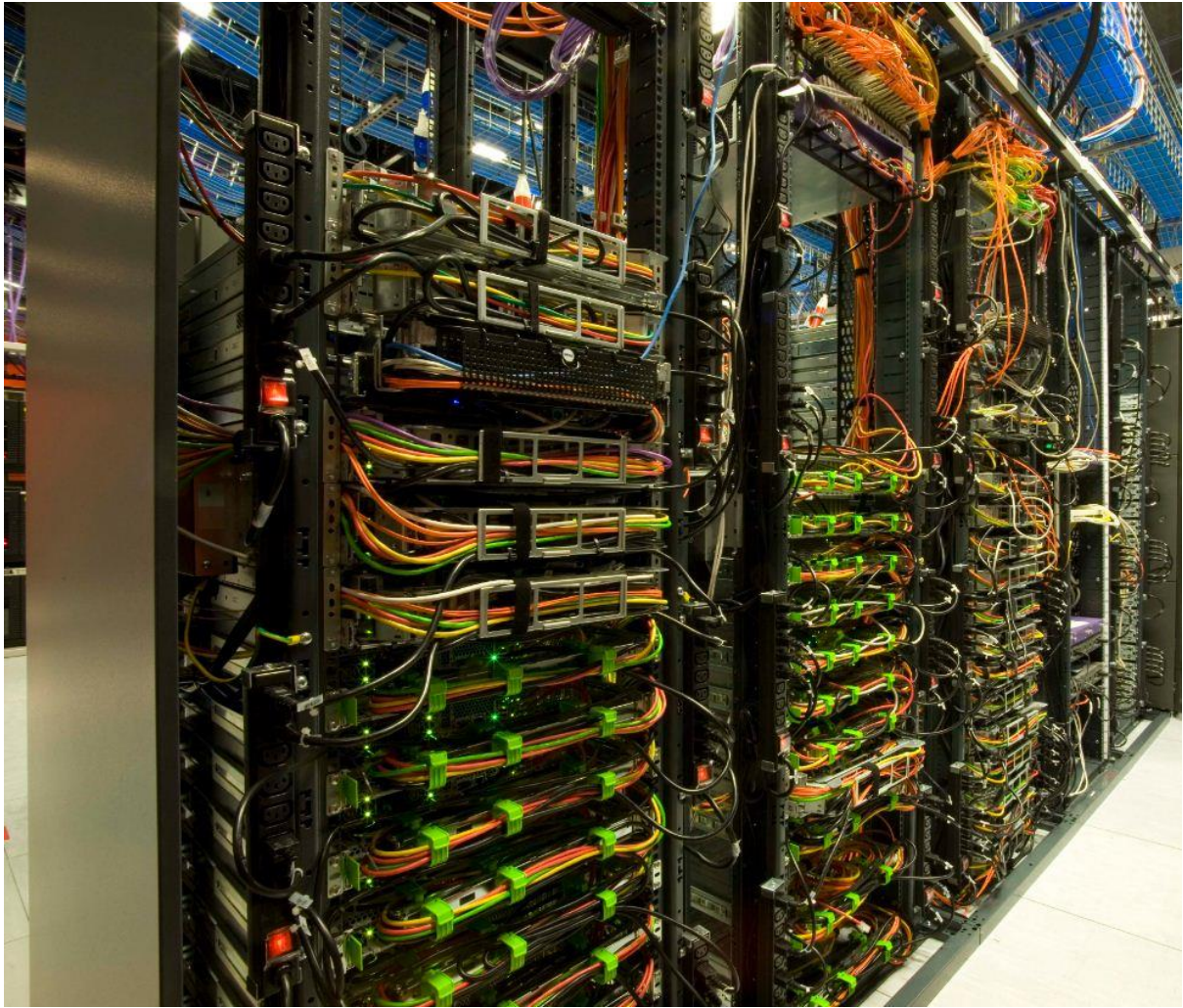

**Figure 12: bDS meets qDS - The Sanger Centre computer cluster to store and analyse 1000 human genomes for medical research**