

USPAS January 2007, Houston, Texas  
Damping Ring Design and Physics Issues

Lecture 1  
Introduction to the ILC Damping Rings

---

Andy Wolski

*University of Liverpool and the Cockcroft Institute*



---

Introduction to the ILC damping rings

---

In this lecture, we shall discuss:

- The role of the damping rings in a linear collider.
- Principles of operation and overall structure.
- Parameter and design constraints.
- Overview of important issues.
- A key technology: the injection and extraction kickers.

## Schematic of present ILC configuration

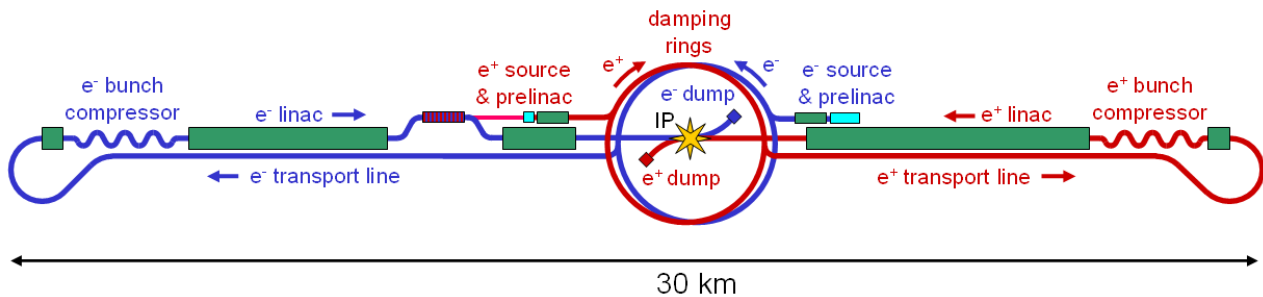

The RF power in the main linacs is pulsed at 5 Hz, with each pulse lasting for 1 ms.

During the machine pulse, a train of bunches is extracted from each damping ring, accelerated to 250 GeV by the main linacs, then collided at the interaction point.

Simultaneously, the sources produce new trains of bunches to fill the damping rings. The fresh bunches are stored in the damping rings during the 200 ms before the next machine pulse.

## Schematic of present ILC configuration

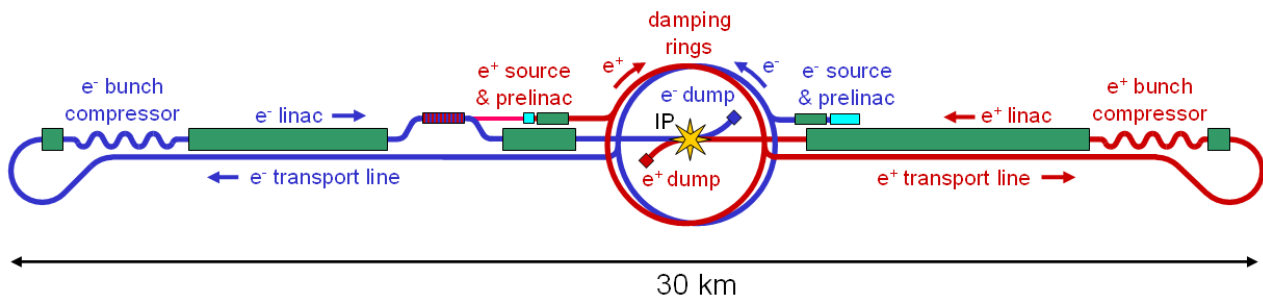

The damping rings perform three essential functions:

- Reduce injected beam emittances by six orders of magnitude in the 200 ms interval between machine pulses.
- Remove jitter from the sources, providing a *highly stable beam* for tuning of downstream systems.
- Delay the beams from the source, allowing for feed-forwards.

## Beam parameters along the ILC

	e <sup>-</sup> prelinac exit	e <sup>+</sup> prelinac exit		Bunch compressor entrance	Bunch compressor exit	Main linac exit	IP
Beam energy	5 GeV	5 GeV		5 GeV	13.5 GeV	250 GeV	250 GeV
Bunch population (maximum)	2×10 <sup>10</sup>	2×10 <sup>10</sup>		2×10 <sup>10</sup>	2×10 <sup>10</sup>	2×10 <sup>10</sup>	2×10 <sup>10</sup>
Normalised horizontal emittance	45 μm	0.01 m		8 μm	8 μm	10 μm	10 μm
Horizontal beam size	~ 300 μm	~ 5 mm		~ 130 μm	~ 130 μm	~ 50 μm	650 nm
Normalised vertical emittance	45 μm	0.01 m		20 nm	20 nm	30 nm	40 nm
Vertical beam size	~ 300 μm	~ 5 mm		~ 5 μm	~ 5 μm	~ 2.5 μm	5 nm
RMS bunch length	~ 1 cm	~ 1cm		9 mm	200 μm	200 μm	200 μm

### The luminosity requirement drives the parameters

$$\mathcal{L} = \frac{n_b N^2 f_{rep}}{4\pi\sigma_x\sigma_y} H_D$$

$n_b$  is the number of bunches in a bunch train.

$N$  is the number of particles in a single bunch.

$f_{rep}$  is the machine pulse repetition rate.

$\sigma_x$  and  $\sigma_y$  are the horizontal and vertical beam sizes at the IP.

$H_D$  is the "enhancement factor" (~ 1.5)

The beam disruption needs to be kept to a minimum

$$D_y = \frac{2r_e N \sigma_z}{\gamma \sigma_y (\sigma_x + \sigma_y)}$$

$r_e$  is the classical radius of the electron.

$\sigma_z$  is the rms bunch length.

$\gamma$  is the relativistic factor.

To maximise the luminosity, we need to minimise the product  $\sigma_x \sigma_y$ , but to minimise the disruption, we need to maximise the sum  $\sigma_x + \sigma_y$ .

The optimum is achieved by making  $\sigma_y \ll \sigma_x$ : i.e. collide very flat beams.

### Some typical parameters

$n_b$	$2 \times 10^{10}$	limited by disruption effects at the IP.
$N$	3000	limited by current in linac and RF pulse length.
$f_{rep}$	5 Hz	limited by cryogenic cooling capacity.
$\sigma_x$	650 nm	optimised for high luminosity and low disruption.
$\sigma_y$	5 nm	as small as possible!

Assuming an enhancement factor  $H_D \approx 1.5$ , we find that with these parameters:

$$\mathcal{L} = \frac{n_b N^2 f_{rep}}{4\pi \sigma_x \sigma_y} H_D \approx 2 \times 10^{34} \text{ cm}^{-2} \text{ s}^{-1}$$

## Main linac beam current

The main linac technology limits the average beam current.

Energy taken from the RF structures by the beam must be replaced.

Filling a standing-wave structure with RF energy is a slow process.

If the beam current is too high, the RF energy will be drained from the accelerating structures more quickly than it can be replaced.

The ILC linac is specified for a maximum average current of 9.5 mA.

This can be increased, but will increase the cost.

If the bunch separation in the main linac is  $T_{sep}$ , then:

$$\frac{eN}{T_{sep}} = 9.5 \text{ mA}$$

The RF pulse length is limited (again, principally by economic considerations) to 1 ms. So if there are a total of  $n_b$  bunches in a bunch train:

$$n_b T_{sep} = 1 \text{ ms}$$

Hence:

$$n_b N = 6 \times 10^{13}$$

## The linac and the damping rings

A train of bunches with 1 ms duration has a total length 300 km.

We must store this bunch train in a damping ring; but we are not likely to build a damping ring with circumference of 300 km!

To make the damping rings practicable, we must take a "compressed" train from the damping rings, and expand it to keep the average current in the linacs within limits.

Decompression of the bunch train is achieved by extracting bunches one at a time from the damping rings: we need a fast kicker that turns on and off in the time ( $\sim 3$  ns) between two bunches.

## Decompressing the bunch train from the damping rings

Consider a damping ring with  $h$  stored bunches, with bunch separation  $\Delta t$ .

If we fire the extraction kicker to extract every  $n^{\text{th}}$  bunch, where  $n$  is *not* a factor of  $h$ , then we extract a continuous train of  $h$  bunches, with bunch spacing  $n \times \Delta t$ .

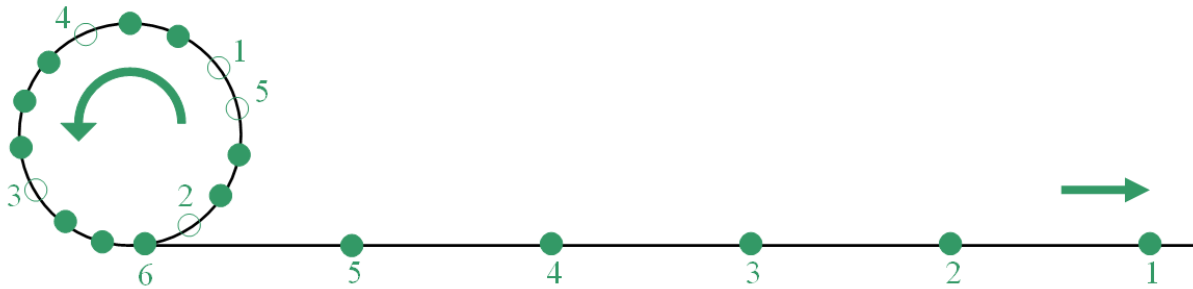

There are two complications:

We would like a continuous train of bunches in the linac, but the damping rings need to have regular gaps in the fill, for ion clearing.

The positrons are produced by the decompressed electron beam, so we have no control over the arrival of positron bunches to refill the damping ring. This places a constraint on beamline lengths in the ILC.

## ILC damping rings design constraints and considerations

The upstream and downstream systems provide design constraints, in terms of the parameter specifications for the injected and extracted beams.

	Electron beam	Positron beam
Machine pulse repetition rate	5 Hz	
Number of bunches per pulse	3000	
Number of particles per bunch	$2 \times 10^{10}$	
Injected normalised emittance	45 $\mu\text{m}$	0.01 m
Injected energy spread	0.1% rms	1% full width
Bunch spacing in main linac	330 ns	
Extracted normalised horizontal emittance	8 $\mu\text{m}$	
Extracted normalised vertical emittance	20 nm	
Extracted rms bunch length	6 mm	
Extracted rms energy spread	<0.15%	

We have to decide the damping rings circumference, beam energy, lattice style...

## ILC damping rings design constraints and considerations: circumference

Optimising the damping ring design is complicated because all the choices are coupled. For example, in rings with large circumference, space-charge effects tend to be more severe, and one would therefore prefer a higher energy. But a higher energy increases the equilibrium emittances; and this affects the choice of lattice style...

For the circumference, cost is a major consideration. Smaller rings would be less expensive. But there are lower limits on the circumference from:

- Kicker performance. The smaller the ring, the smaller the separation between bunches, and the faster the kickers need to be to inject and extract individual bunches.
- Electron cloud and ion effects. With smaller bunch separations, the electron cloud and ion effects can be more severe.

Other considerations include operational reliability and tuning issues, which tend to favour smaller rings with fewer components.

The present damping ring designs have a circumference of 6.7 km, which pushes the limits on kicker performance and on electron cloud effects.

## ILC damping rings design constraints and considerations: beam energy

A higher beam energy is favoured by:

- Collective effects. Sensitivity to collective effects (instabilities, intrabeam scattering, space charge etc.) is reduced at higher beam energies.
- Acceptance. With a given normalised injected emittance, the beam size is smaller at higher energies (because of adiabatic damping as the beam is accelerated), and easier to capture in the ring.
- Damping rates. Higher beam energy results in faster damping from synchrotron radiation.

A lower beam energy is favoured by:

- Equilibrium emittances. Lower emittances (at least at low bunch charge) are easier to achieve in lower energy rings. The normalised natural emittance scales as the cube of the energy in a given lattice.
- Cost. Lower energy rings require less powerful magnets, and lower RF voltage.

The present damping rings design have a beam energy of 5 GeV, which appears to be a reasonable compromise between the competing effects.

## ILC damping rings design constraints and considerations: wiggler

---

There are numerous other design choices that need to be made for various technical subsystems. An example is the wiggler, which is required to provide the necessary damping rates to reduce the beam emittances in the specified time.

There are three principal choices for the wiggler technology:

- permanent magnet
- normal-conducting electromagnet
- superconducting

Issues to consider include aperture, field strength and field quality, construction and operating cost, and vulnerability to radiation damage.

The present specification is for a superconducting wiggler; the CESR-c superferric wigglers have demonstrated the required field strength with very good quality, and wide aperture.

## ILC damping rings design constraints and considerations

---

The present configuration for the damping rings appears to satisfy the necessary criteria, though further research and development is needed before the design can be fully validated.

Key areas for further R&D include:

- injection and extraction kickers (Lecture 1)
- electron cloud effects (Lecture 9)

The ILC has a configuration control system, which allows changes to the configuration to be made on grounds of technical performance or cost.

Future changes to the damping rings configuration are possible.



## ILC damping rings parameters compared with existing machines

	KEK-ATF	LBNL-ALS	SLAC-PEP II LER	ILC DR	
Circumference	139 m	196 m	2200 m	6700 m	
Beam energy	1.28 GeV	1.9 GeV	3.1 GeV	5 GeV	
Average current	70 mA	400 mA	2450 mA	400 mA	
Bunch population	$\sim 10^{10}$	$0.6 \times 10^{10}$	$7 \times 10^{10}$	$1 \times 10^{10}$	$2 \times 10^{10}$
Number of bunches	20	272	1588	5782	2767
Bunch spacing	2.8 ns	2 ns	4.2 ns	3.1 ns	6.2 ns
Transverse damping time	28 ms	9 ms	70 ms	25 ms	
Natural emittance	1 nm	7 nm	30 nm	0.8 nm	
Vertical emittance	4.5 pm	$\sim 10$ pm	1400 pm	2 pm	
RMS bunch length	4 mm	7 mm	11 mm	9 mm	
RMS energy spread	0.055%	0.1%	0.07%	0.13%	
RF voltage	770 kV	1 MV	4 MV	24 MV	
RF frequency	714 MHz	500 MHz	476 MHz	650 MHz	

## The KEK-ATF prototype damping ring (and largest LC test facility)

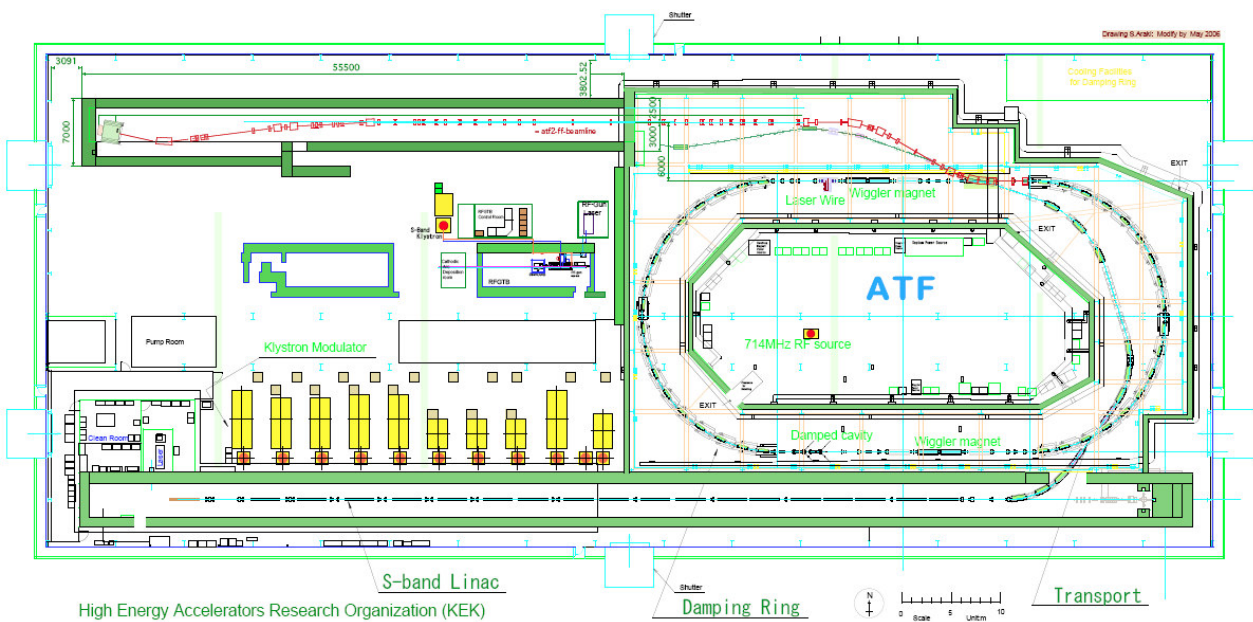

The main components are a 1.28 GeV S-band linac, a 1.28 GeV storage ring, and an extraction line. The extraction line is presently being extended (ATF2) to provide a test facility for linear collider beam delivery systems.

(Clockwise) ATF injector; damping ring; laser wire; extraction line

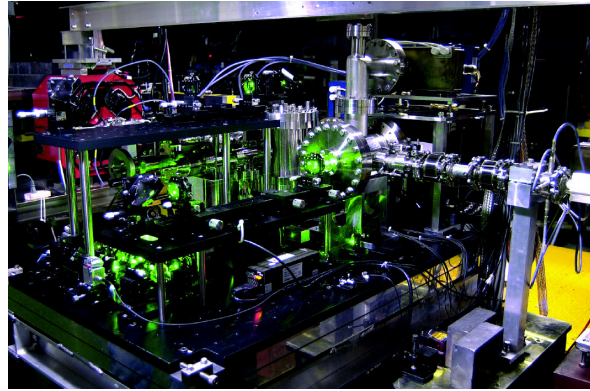
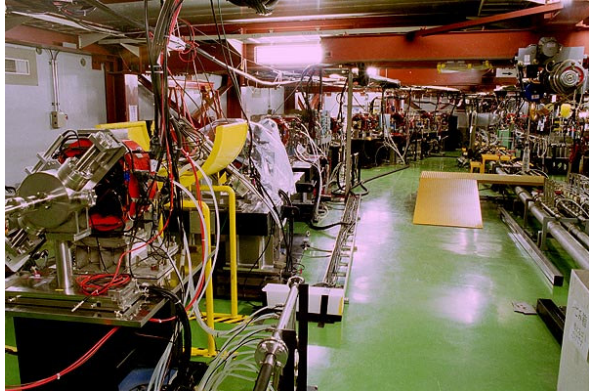

Damping Ring Designs and Issues

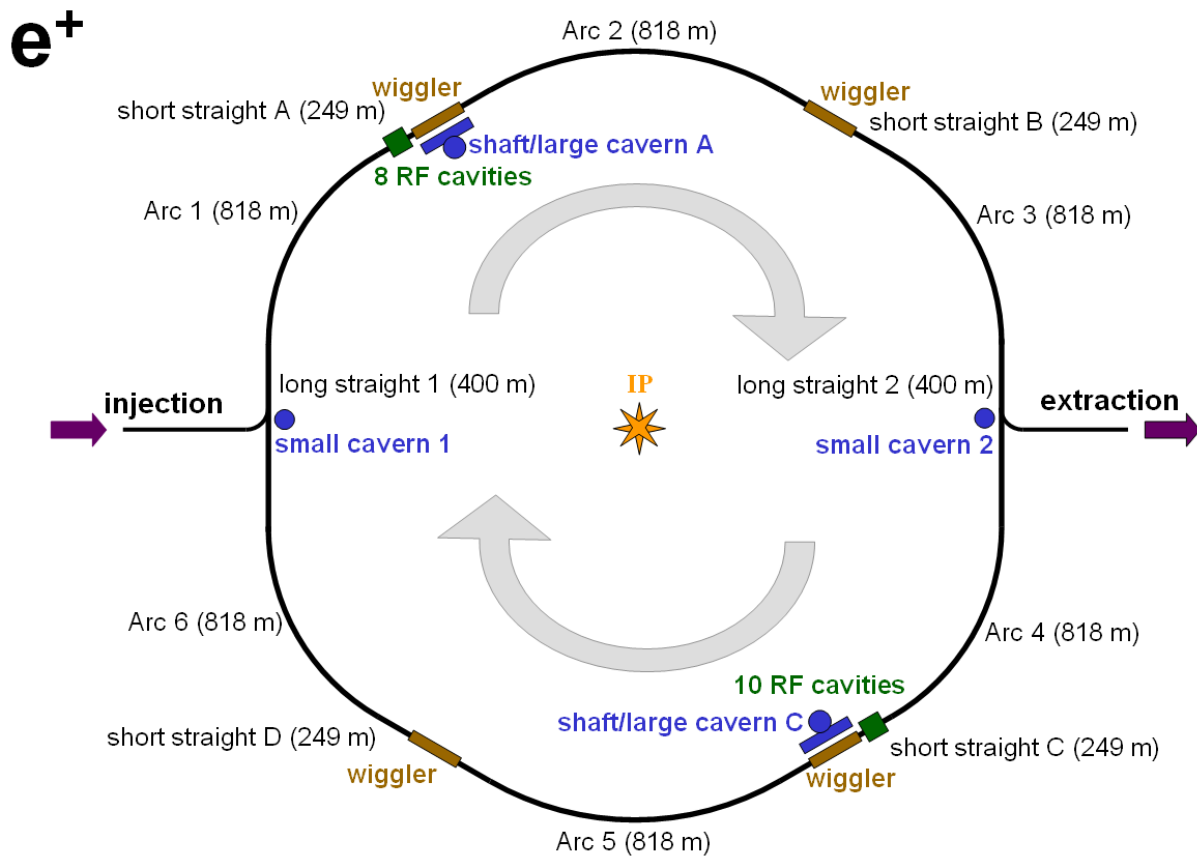

## Key issues for the ILC damping rings

The three main challenges for the ILC damping rings are:

- acceptance of a large (several mm), high-power (225 kW) beam from the positron source with negligible particle losses;
- achieving demanding specifications for beam quality (very low emittance);
- **maintaining beam quality and precise stability at high bunch charges and beam currents.**

There are many design and operational issues that have to be addressed to meet these challenges, for example:

- lattice design to achieve a sufficient dynamic aperture;
- lattice design to reduce sensitivity to misalignments and coupling errors;
- tuning for low emittance;
- design and construction of vacuum system with low impedance to avoid beam instabilities;
- devising and implementing mitigation techniques for ion and electron cloud effects.

## Key issues for the ILC damping rings

In this course, we shall focus mainly on the beam dynamics issues.

### Technical systems

Injection/extraction kickers (Lecture 1)

Magnets (including wigglers), RF, vacuum, instrumentation and diagnostics, feedback systems, support and alignment, conventional facilities...

### Single-particle dynamics

Lattice design for low-emittance storage rings (Lecture 3)

Dynamics with damping wigglers (Lecture 4)

Dynamic aperture and acceptance (Lecture 4)

Low-emittance tuning: correction of coupling errors (Lecture 5)

### Multi-particle dynamics

Coupled-bunch instabilities: resistive-wall, HOMs... (Lecture 6)

Intensity-dependent emittance growth: space charge and IBS (Lecture 7)

Classical single-bunch instabilities (Lecture 8)

Ion and electron cloud effects (Lecture 9)

## Kickers provide a deflecting field to direct incoming bunches onto the orbit

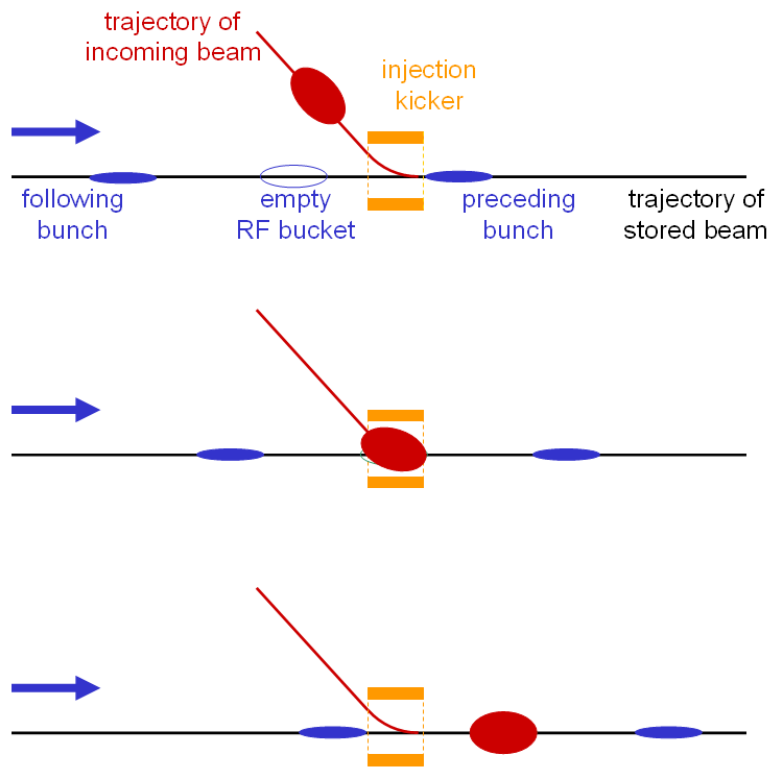

1. Kicker is OFF.  
“Preceding” bunch exits  
kicker electrodes.  
Kicker starts to turn ON.

2. Kicker is ON.  
“Incoming” bunch is  
deflected by kicker.  
Kicker starts to turn OFF.

3. Kicker is OFF by the  
time the following  
bunch reaches the  
kicker.

## Injection and extraction kickers

In the ILC damping rings, we need to inject and extract bunches individually, without affecting bunches

Several different types of fast kicker are possible. For the ILC damping rings, the injection/extraction kickers are composed of two parts:

- fast, high-power pulser;
- stripline electrodes.

Several technologies are possible for the fast, high-power pulser. The parameters for the ILC damping rings are very challenging, and pulser development is on-going.

The stripline electrodes are conceptually straightforward: they consist of two plates, connected to a high-voltage line, between which the beam travels.

For the ILC damping rings, the stripline design is fairly challenging, because of the need to provide a large on-axis field while maintaining field quality and physical aperture; and the need to match the impedance to the power supply.

## Example: stripline electrodes for DAΦNE

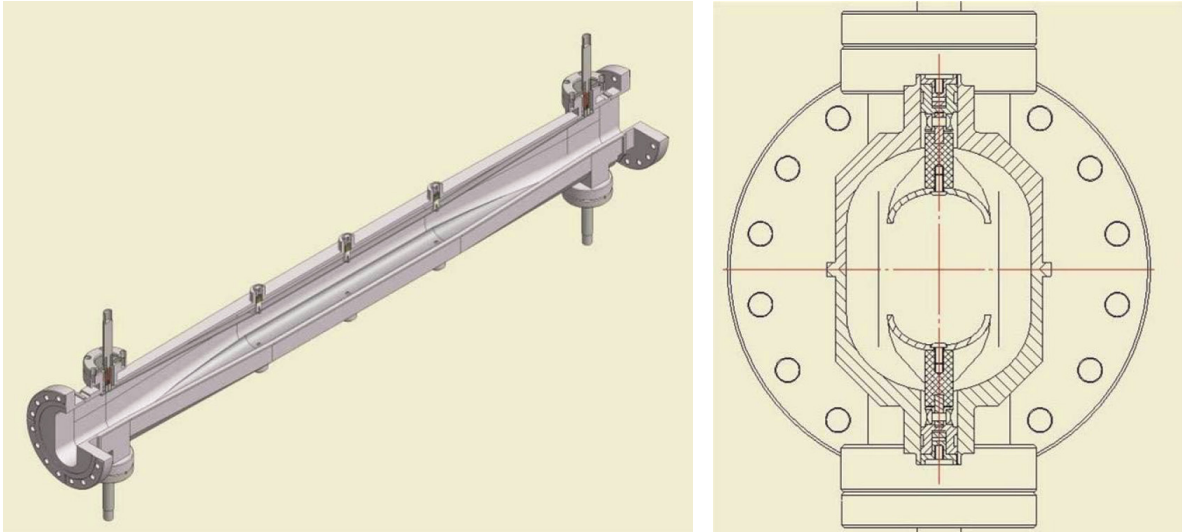

Stripline electrodes developed for fast kicker in DAΦNE.

(D. Alesini, F. Marcellini, P. Raimondi, S. Guiducci, "Fast kickers R&D at LNF-INFN", presented at ILCDR06)

## Injection and extraction kickers: a simplified model

Let us take a simplified model of the stripline electrodes, consisting of two infinite parallel plates. The beam travels in the  $+z$  direction. We apply an alternating voltage between the plates:

$$V = V_0 e^{i\alpha x}$$

From Maxwell's equations, there are electric and magnetic fields between the plates:

$$E_x = E_0 e^{i(kz - \alpha x)} \quad B_y = \frac{E_0}{c} e^{i(kz - \alpha x)}$$

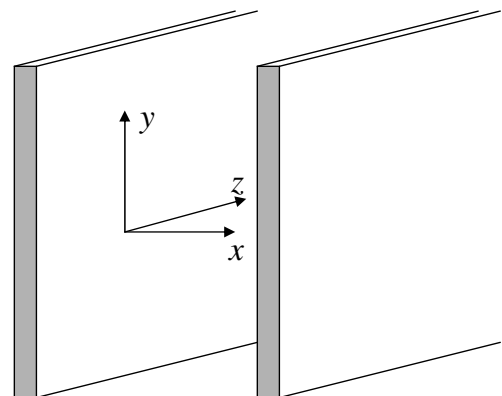

A particle traveling in the  $+z$  direction with speed  $\beta c$  will experience a force:

$$F_x = q(E_x - v_z B_y) = q(1 - \beta) E_0 e^{-i(1-\beta)\alpha x}$$

For an ultra-relativistic particle,  $\beta \approx 1$ , and the electric and magnetic forces almost exactly cancel: the resultant force is small. But for a particle traveling in the opposite direction to the electromagnetic wave,  $\beta \approx -1$ , and the resultant force is twice as large as would be expected from the electric force alone.

## Injection and extraction kickers: a simplified model

Let us calculate the deflection of a particle traveling between a pair of stripline electrodes. Let us suppose that there is a voltage pulse of amplitude  $V$  and length  $2L$  traveling along the electrodes, which consist of infinitely wide parallel plates of length  $L$  separated by a distance  $d$ :

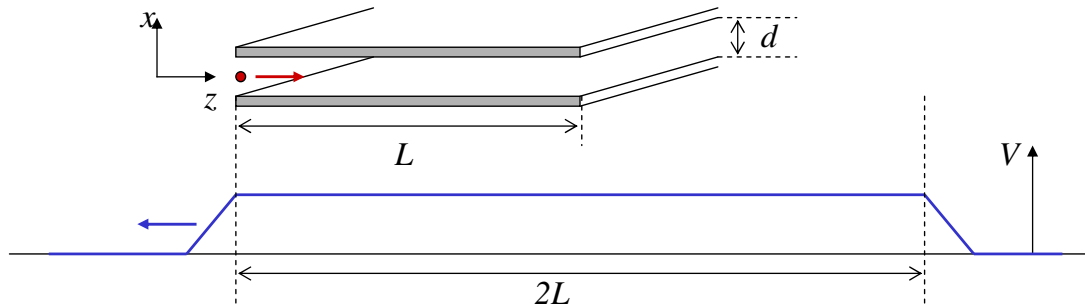

The change in the (normalised) horizontal momentum of the particle is:

$$\Delta p_x = \frac{F_x L}{p_0 c} = 2 \frac{V L}{E/e d}$$

where  $E$  is the beam energy. In practice, we can account for the fact that the electrodes are not infinite parallel plates by including a geometry factor,  $g$ .

## Injection and extraction kickers: a simplified model

How large a kick is needed? Consider the extraction optics:

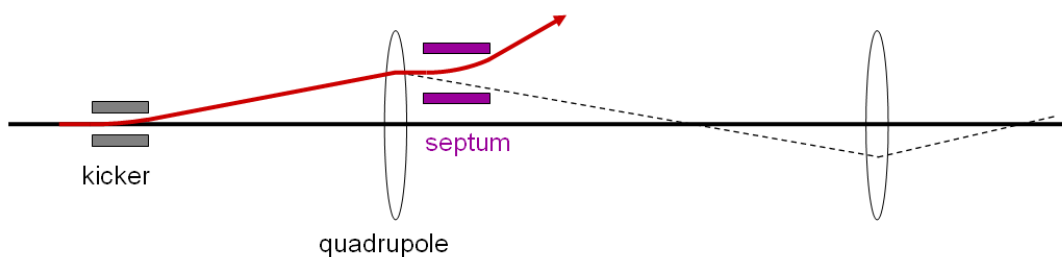

Assuming a distance from the kicker to the septum of 50 m, and a required beam offset from the reference trajectory of 30 mm at the septum, the necessary kick is:

$$\Delta p_x = 2g \frac{V L}{E/e d} = \frac{0.03}{50} = 0.6 \text{ mrad}$$

If we assume  $E/e = 5$  GV,  $L = 30$  cm,  $d = 20$  mm and  $g = 0.7$ , we find that the required voltage pulse is 143 kV. This is not realistic for a  $\sim$  ns pulser! The solution is to use multiple pairs of striplines, each producing a  $\sim 10$  kV kick.

## The length of the stripline adds to the effective rise and fall time

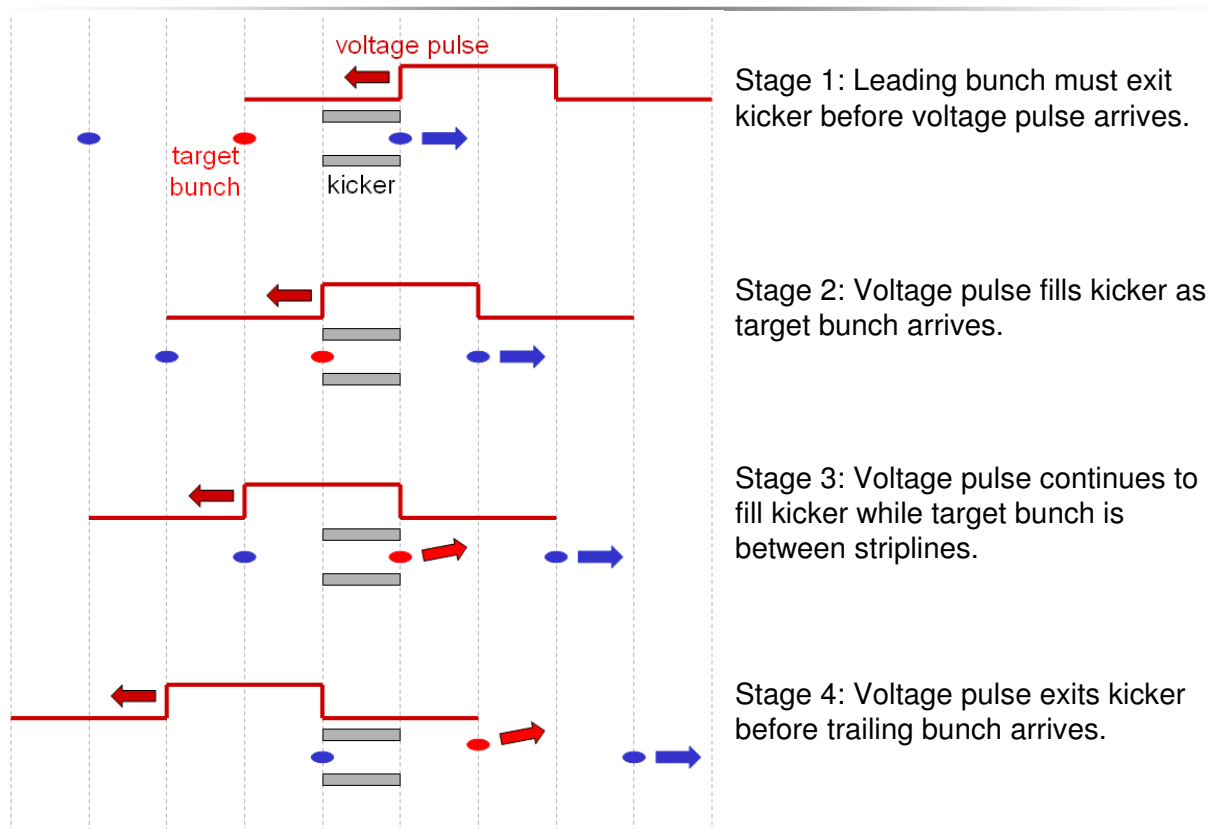

## ILC damping rings fast kicker pulser parameters

The pulsers for the damping rings injection/extraction kickers must meet very demanding specifications:

- peak voltage 10 kV
- rise and fall times  $\sim 1$  ns
- flat-top 2 ns
- "burst" repetition rate 6 MHz
- "burst" pulse length 1 ms
- pulse-to-pulse amplitude stability better than 0.1%

Development of a technology to meet these specifications is the goal of an active R&D program.

Several approaches look promising...

# High voltage pulsers for fast kickers: drift step recovery diode (DSRD)

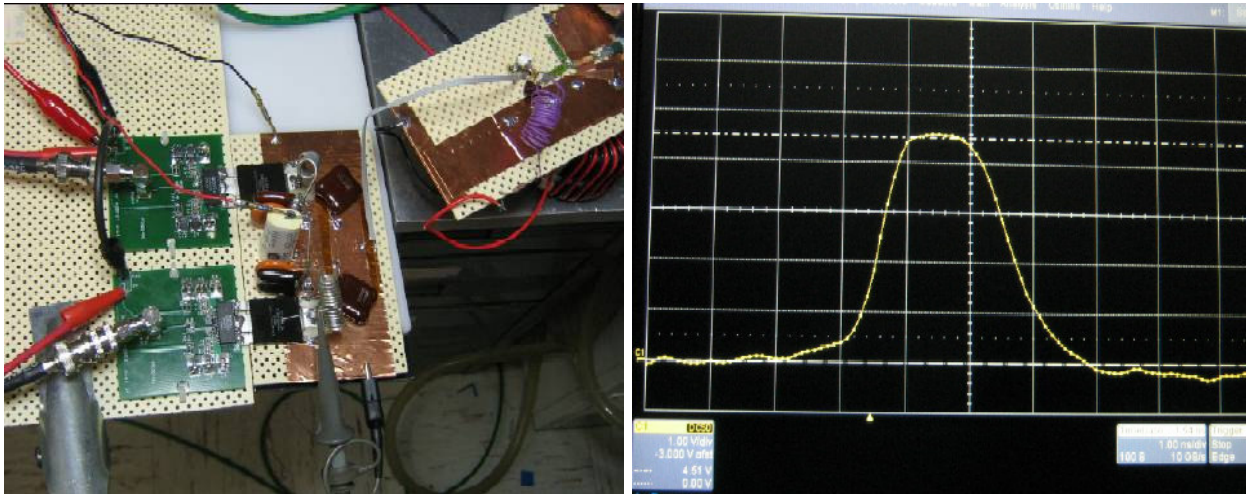

Tests of DSRD fast pulser. Output voltage 2.7 kV; horizontal scale 1 ns/division. (Anatoly Krasnykh)

# High voltage pulsers for fast kickers: inductive adder

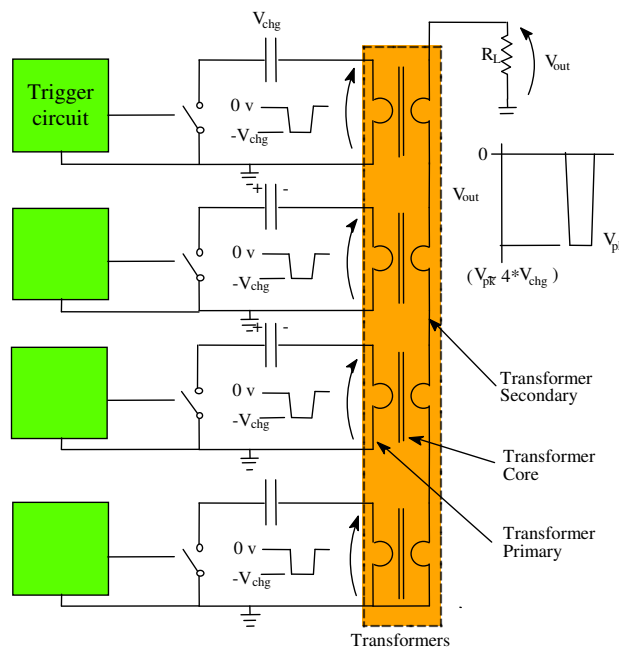

Inductive adder concept: simplified schematic. (Ed Cook)



## High voltage pulsers for fast kickers: inductive adder

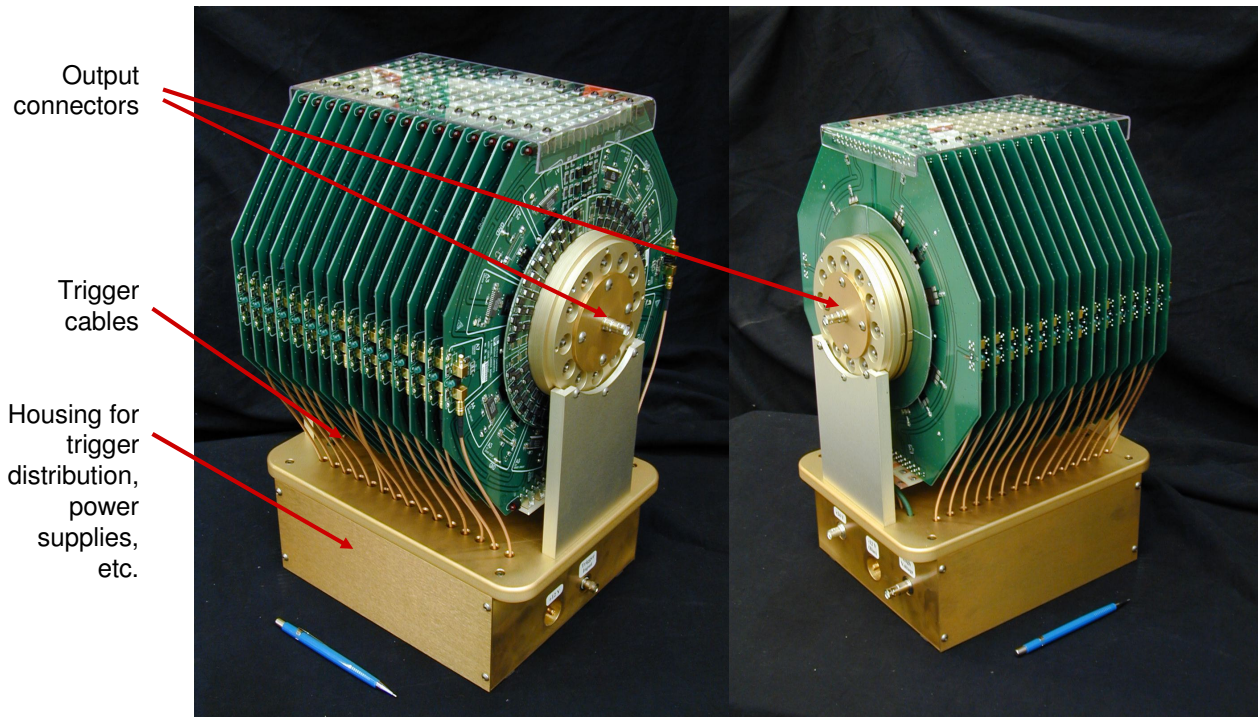

Prototype inductive adder for tests at KEK-ATF. (Ed Cook)

## High voltage pulsers for fast kickers: inductive adder

7 ns rise/fall times demonstrated in bench tests of prototype inductive adder. (Ed Cook)

Simultaneous bi-polar outputs: 50  $\Omega$  load on each end.

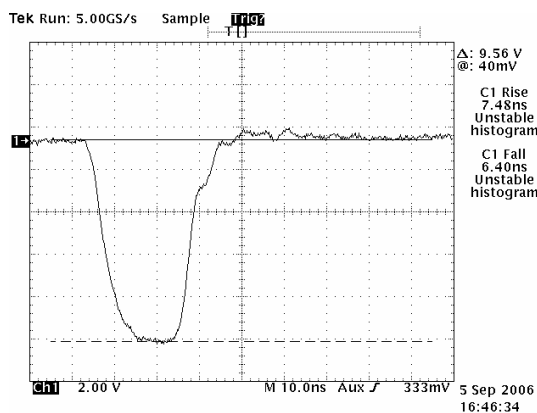

Negative output:  
-9.6 kV flat-top

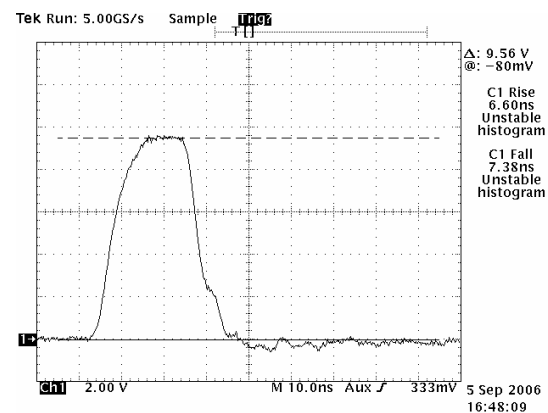

Positive output:  
+9.6 kV flat-top

## High voltage pulsers for fast kickers: fast ionization dynistor (FID)

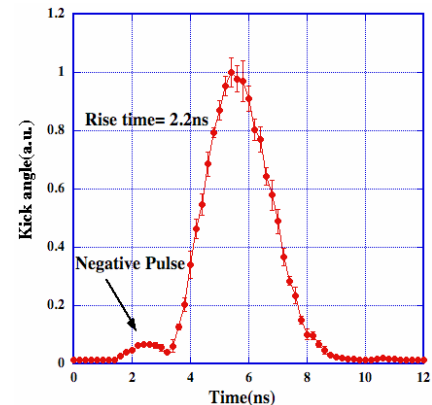
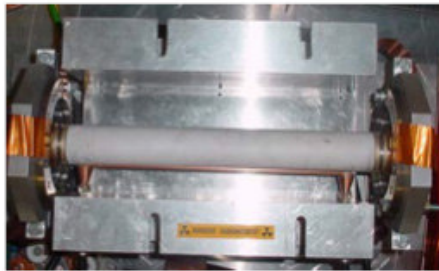
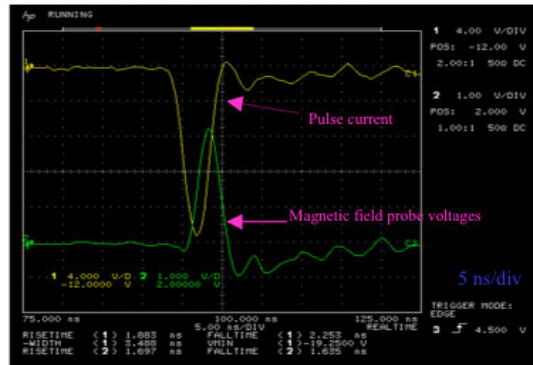
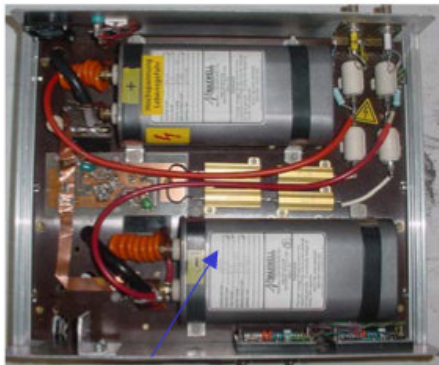

Tests of FID fast pulser at KEK-ATF.  
(T. Naito)

## Summary

The ILC damping rings must provide beams of very high quality and stability for the tuning and operation of downstream systems.

The parameters of upstream and downstream systems (particularly the sources and the main linac) set design constraints on the damping rings.

Parameter choices for the damping rings are usually a compromise between competing effects. The present configuration specifies two 6.7 km storage rings (one for positrons, and one for electrons) operating at beam energies of 5 GeV.

The parameters for the present ILC damping rings design are similar to some other operating facilities, though more demanding in terms of beam quality and stability. No single facility has demonstrated the full operational performance required for the ILC damping rings.

Continued research and development is required to validate the present configuration. The injection and extraction kickers are particularly demanding, and are the focus of a very active R&D program.

## Summary

---

A wide range of beam dynamics effects threaten to impact or limit the performance of the damping rings. A full understanding of these effects will be essential in producing a viable design at a reasonable cost.

In the following lectures, we will explore many of these effects.

*Enjoy the rest of the course!*